

Original instructions
PA3500/4200

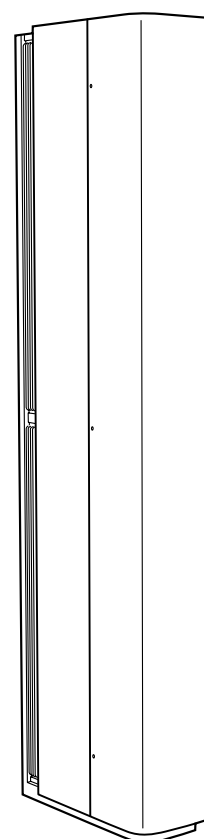
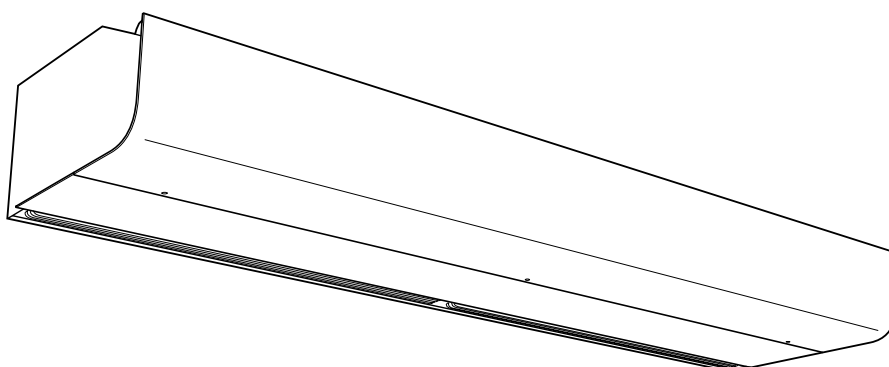

SE 27

EN ... 33

NO ... 38

DE ... 44

ES ... 51

FR ... 57

IT ... 64

NL ... 71

PL ... 78

RU ... 84

FI ... 90

- SE** Introduktionssidorna består huvudsakligen av bilder. För översättning av de engelska texter som används, se respektive språksidor.
- EN** The introduction pages consist mainly of pictures. For translation of the English texts used, see the respective language pages.
- NO** Introduksjonssidene består hovedsakelig av bilder. For oversettelse av de engelske tekstene, se de respektive språksidene.
- FR** Les pages de présentation contiennent principalement des images. Pour la traduction des textes en anglais, consultez la page correspondante à la langue souhaitée.
- DE** Die Einleitungsseiten bestehen hauptsächlich aus Bildern. Für die Übersetzung der verwendeten Texte in englischer Sprache, siehe die entsprechenden Sprachseiten.
- ES** Las páginas introductorias contienen básicamente imágenes. Consulte la traducción de los textos en inglés que las acompañan en las páginas del idioma correspondiente.
- NL** De inleidende pagina's bevatten hoofdzakelijk afbeeldingen. Voor een vertaling van de gebruikte Engelse teksten, zie de pagina's van de resp. taal.
- IT** Le pagine introduttive contengono prevalentemente immagini. Per le traduzioni dei testi scritti in inglese, vedere le pagine nelle diverse lingue.
- PL** Początkowe strony zawierają głównie rysunki. Tłumaczenie wykorzystanych tekstów angielskich znajduje się na odpowiednich stronach językowych.
- RU** Страницы в начале Инструкции состоят в основном из рисунков, схем и таблиц. Перевод встречающегося там текста приведен в разделе RU.
- FI** Esittelysivut koostuvat lähinnä kuvista. Suvuilla olevien enlanninkielisten sanojen käännökset löytyvät ko. kielisivuilta.

PA3500

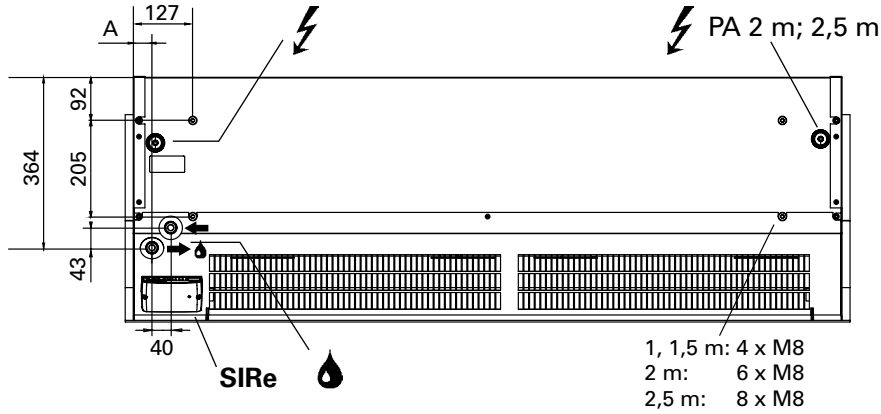
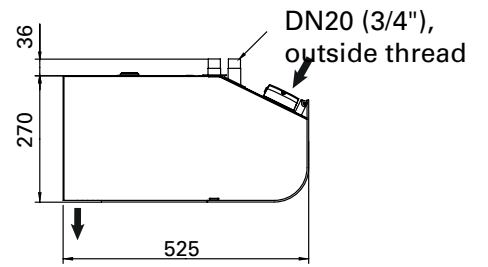
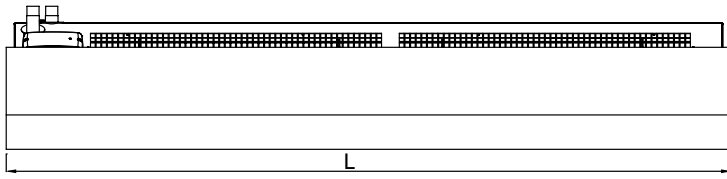
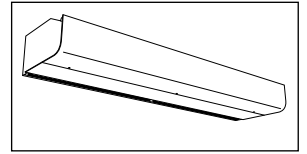

	L [mm]	A [mm]
PA3510	1039	40
PA3515	1549	40
PA3520	2039	40
PA3525	2549	39

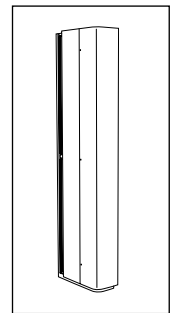
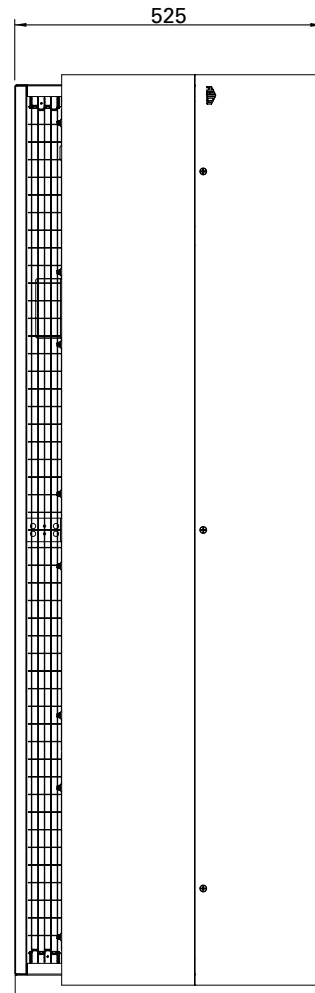
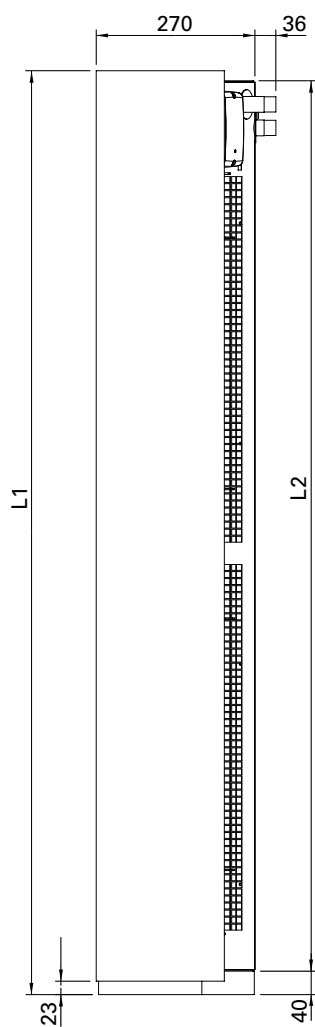

	L1 [mm]	L2 [mm]
PA3515	1572	1515
PA3520	2062	2004
PA3525	2572	2515

PA4200

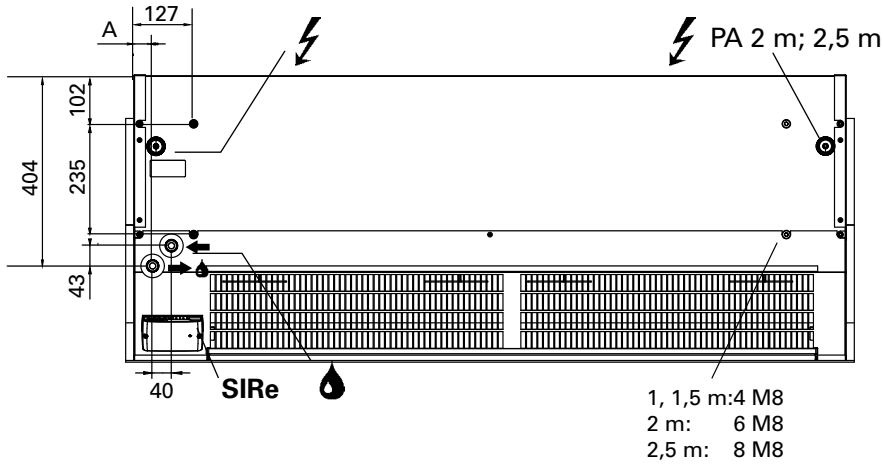
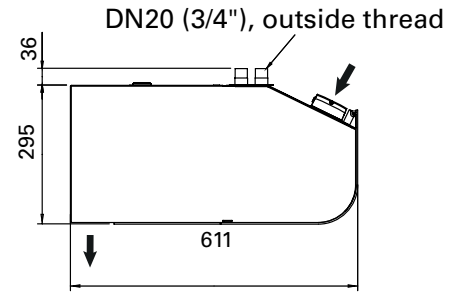
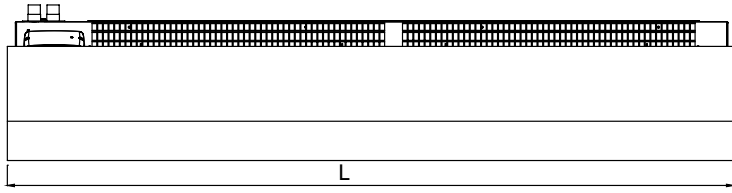
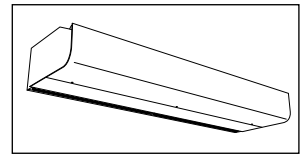

	L [mm]	A [mm]
PA4210	1039	40
PA4215	1549	40
PA4220	2039	40
PA4225	2549	39

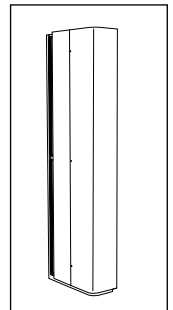
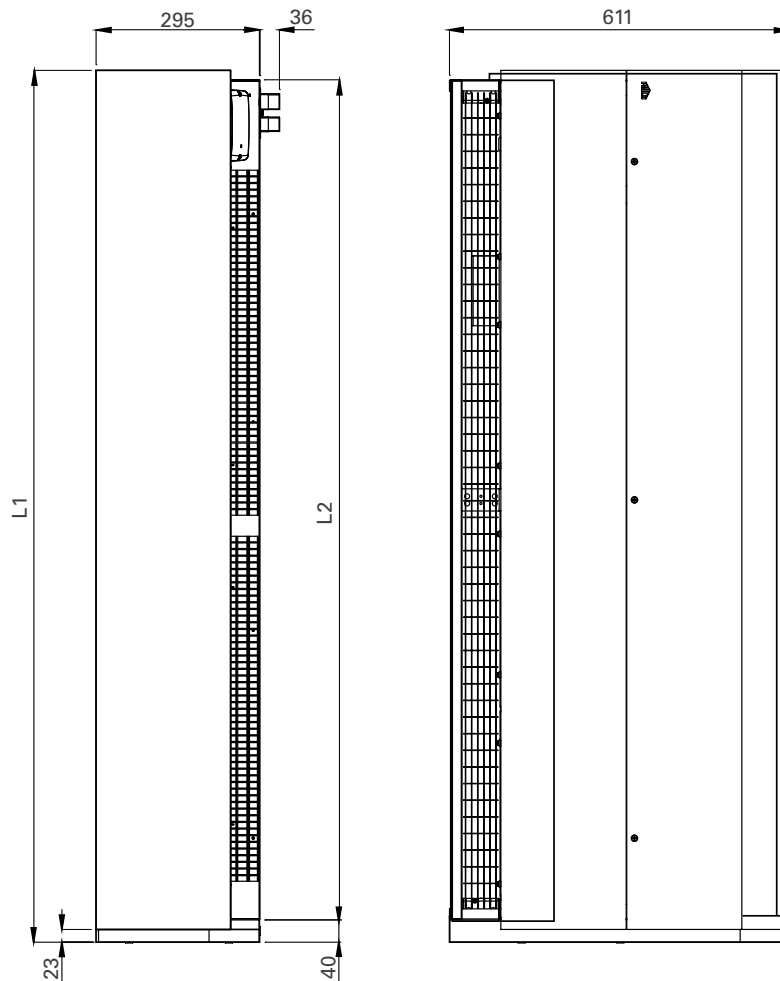

	L1 [mm]	L2 [mm]
PA4215	1572	1515
PA4220	2062	2004
PA4225	2572	2515

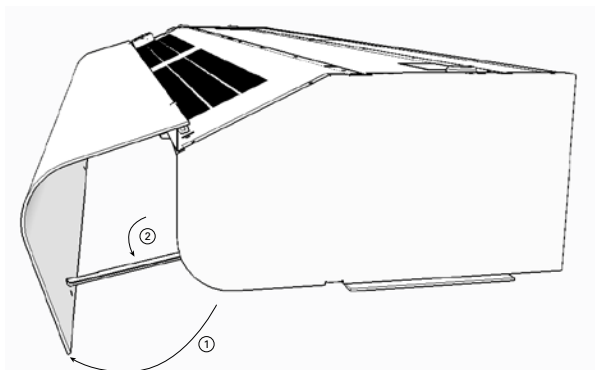

Fig. 1A: Open the unit by raising the front panel. The front is blocked in open position with the front hatch hook.

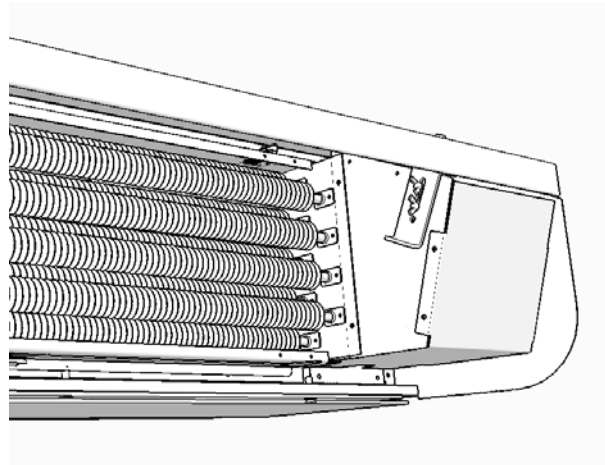

Fig. 1B: When the front has been removed it is important to be sure it is firmly seated in the front locks again.

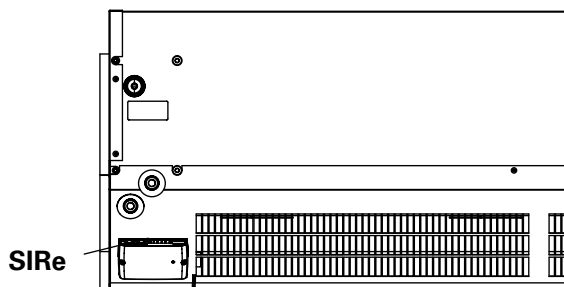

Fig. 2: Control card SIRe is integrated in the air curtain at delivery.

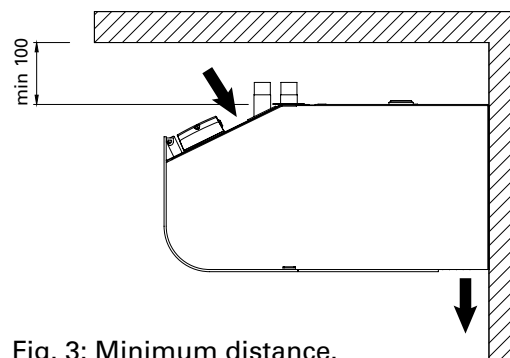

Fig. 3: Minimum distance.

Filling the water coil

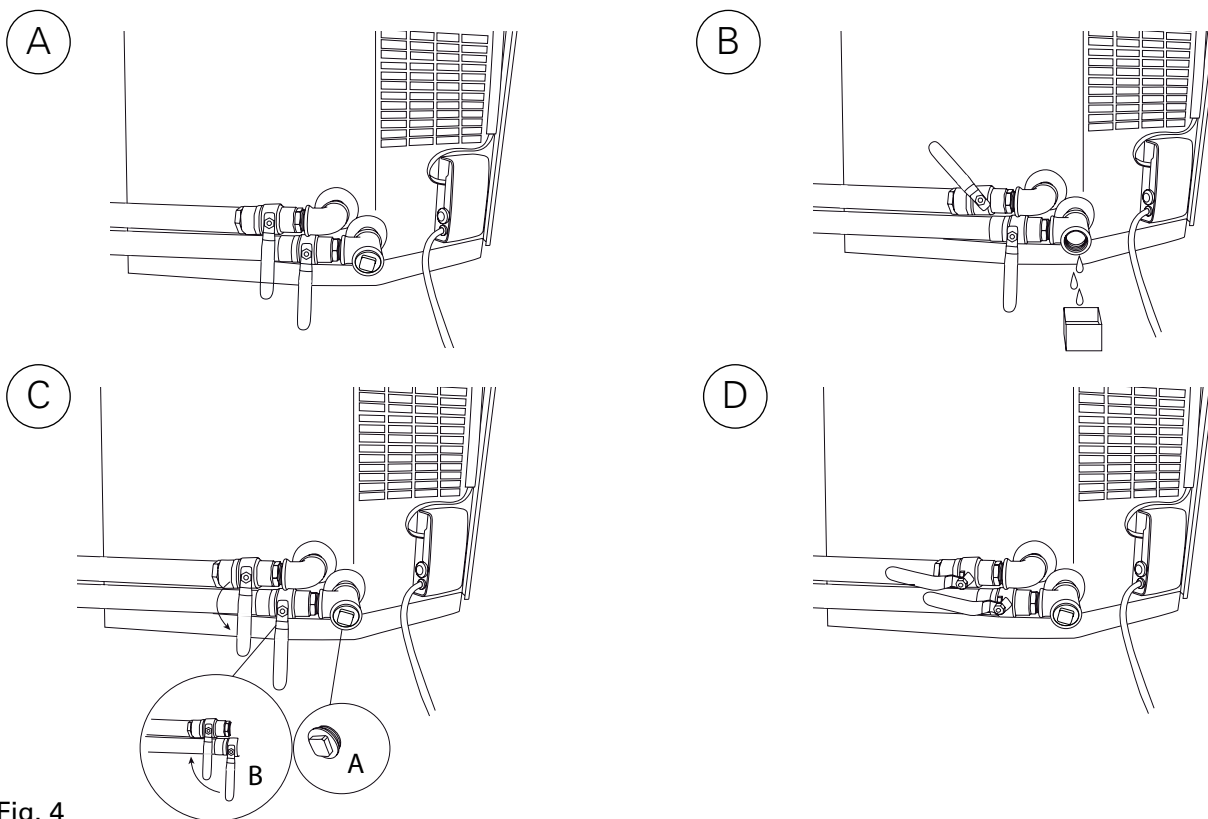
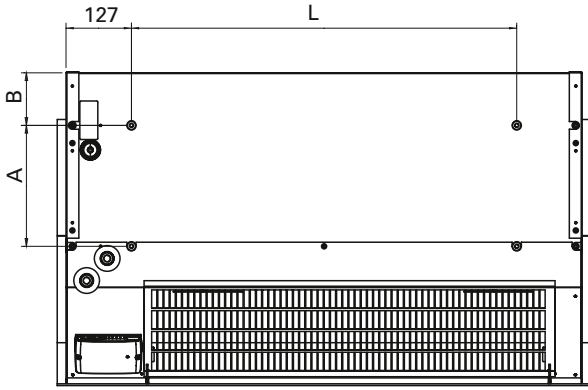

Fig. 4

PA3500/4200

PA3510/PA3515/PA4210/PA4215



	A [mm]	B [mm]
PA3500	205	92
PA4200	235	102

	L [mm]
PA3510	750
PA4210	750
PA3515	1260
PA4215	1260

PA3520/PA4220

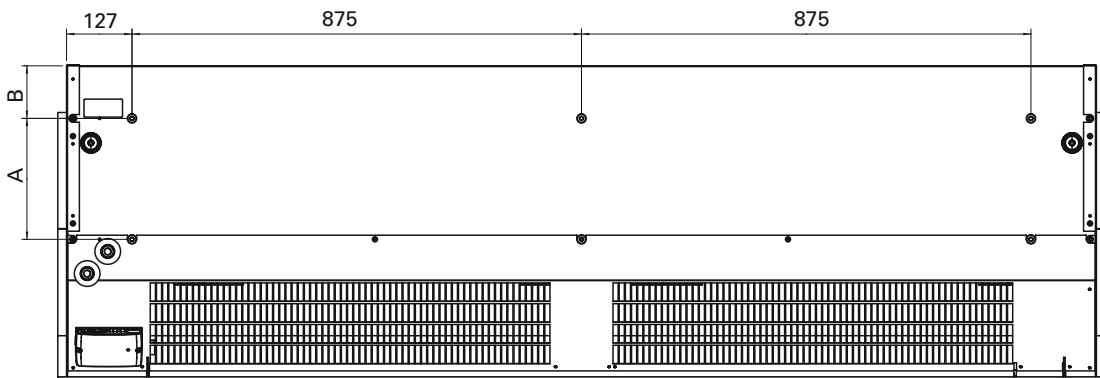

PA3525/PA4225

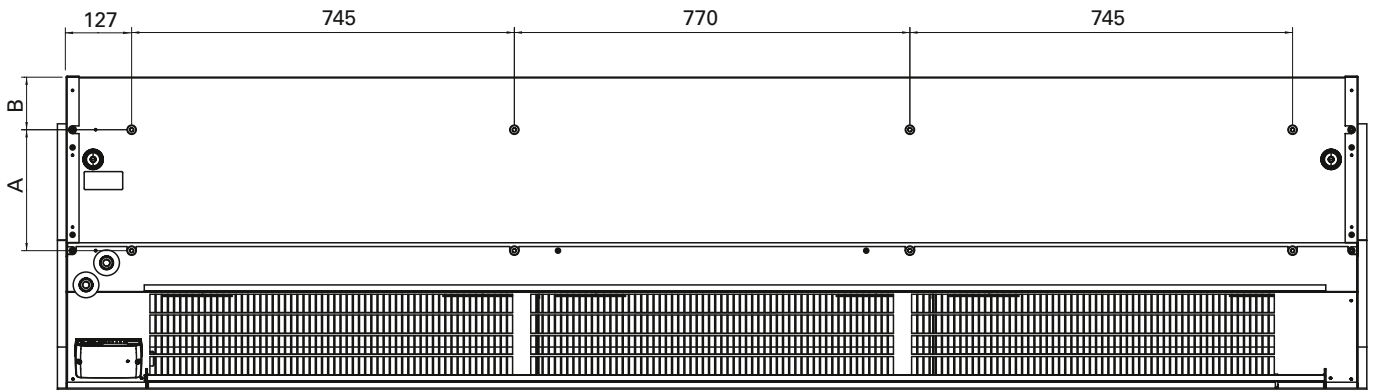

Fig. 5: M8-holes for mounting.

PA3500/4200 + PA34WB

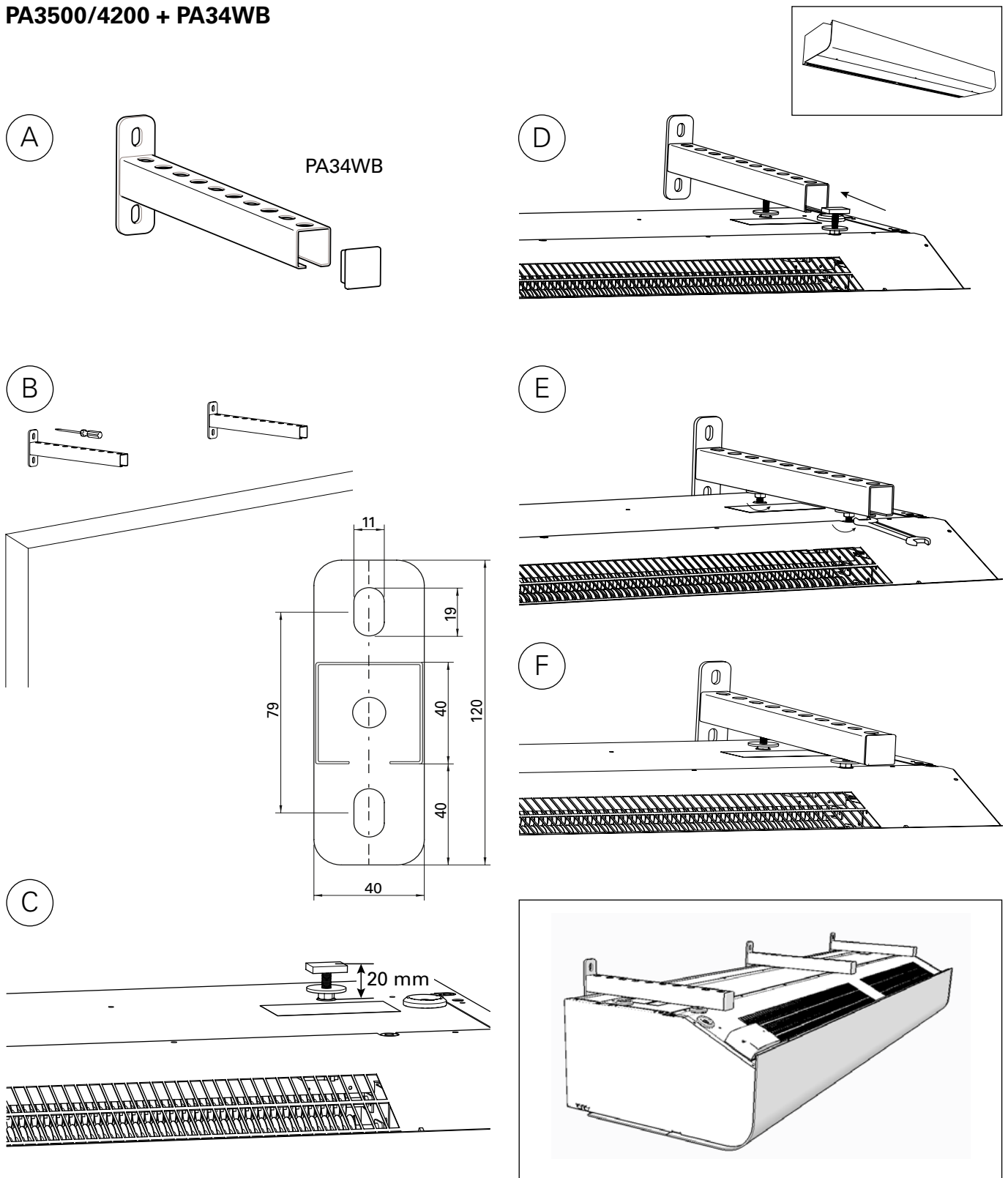

Fig. 6: See separate manual for PA34WB.

Type		Quantity included	Length	Fig.	E-nr (SE)	RSK-nr (SE)	EL-nr (NO)
PA34WB15	PA3510/15, PA4210/15	2 pcs	400 mm	Fig. 6	87 505 68	673 91 18	49 320 82
PA34WB20	PA3520, PA4220	3 pcs	400 mm	Fig. 6	87 505 69	673 91 19	49 320 83
PA34WB30	PA3525, PA4225	4 pcs	400 mm	Fig. 6	87 505 70	673 91 20	49 320 84

Accessories

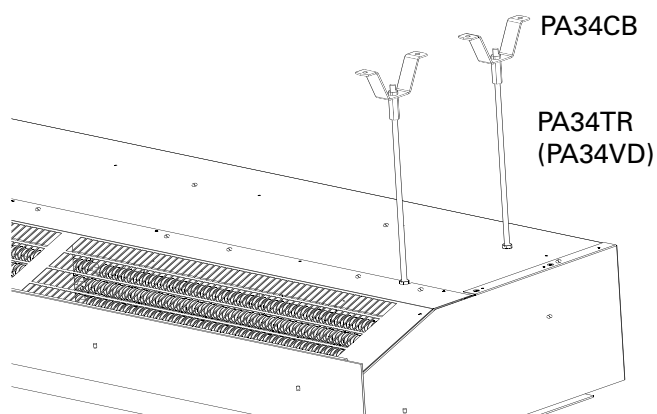

Fig. 7: PA34TR + PA34CB + PA34VD.
See separate manual for PA34TR.

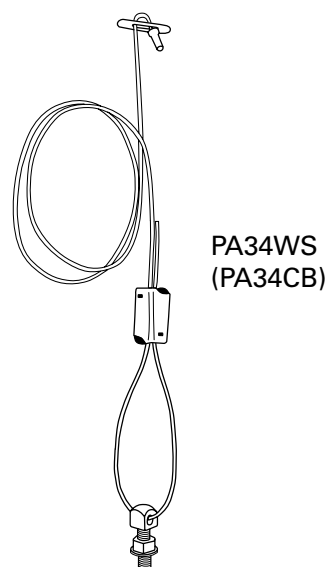
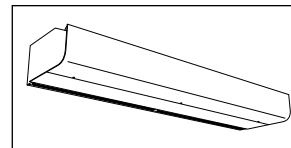

Fig.8: PA34WS + PA34CB
See separate manual for PA34WS.



Type		Quantity included	Length	E-nr (SE)	RSK-nr (SE)	EL-nr (NO)
PA34CB15	PA3510/15, PA4210/15	4 pcs		87 505 71	673 91 21	49 320 59
PA34CB20	PA3520, PA4220	6 pcs		87 505 72	673 91 22	49 320 60
PA34CB30	PA3525, PA4225	8 pcs		87 505 73	673 91 23	49 320 61
PA34WS15	PA3510/15, PA4210/15	4 pcs	3 m	87 505 37	673 90 97	49 322 05
PA34WS20	PA3520, PA4220	6 pcs	3 m	87 505 38	673 90 98	49 322 06
PA34WS30	PA3525, PA4225	8 pcs	3 m	87 505 39	673 90 99	49 322 07
PA34TR15	PA3510/15, PA4210/15	4 pcs	1 m	87 505 32	673 90 94	
PA34TR20	PA3520, PA4220	6 pcs	1 m	87 505 34	673 90 95	
PA34TR30	PA3525, PA4225	8 pcs	1 m	87 505 35	673 90 96	
PA34VD15	PA3510/15, PA4210/15	4 pcs		87 505 74	673 91 24	
PA34VD20	PA3520, PA4220	6 pcs		87 505 75	673 91 25	49 320 96
PA34VD30	PA3525, PA4225	8 pcs		87 505 76	673 91 26	49 320 97

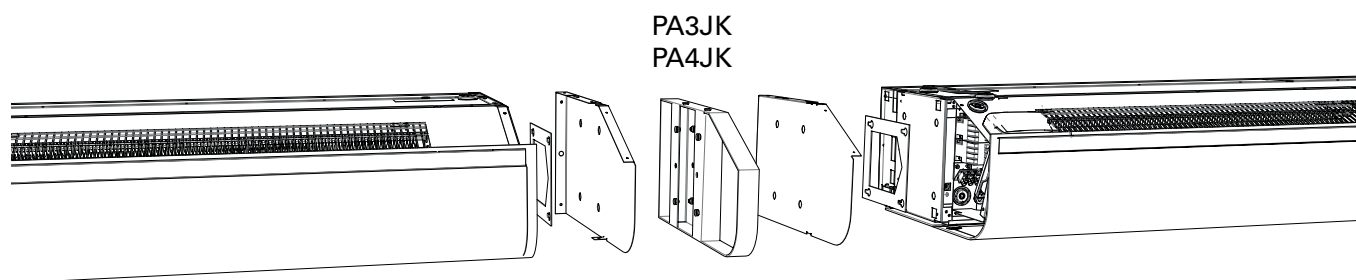

Fig. 9: See separate manual for PA3JK / PA4JK.

Type		E-nr (SE)	RSK-nr (SE)	EL-nr (NO)
PA3JK	PA3500	87 515 22	673 11 96	54 300 07
PA4JK	PA4200	87 515 23	673 11 97	54 300 08

Accessories

Type		Length	E-nr (SE)	RSK-nr (SE)
PA3XT10	PA3510	130-200 mm	87 505 42	673 91 00
PA3XT15	PA3515	130-200 mm	87 505 43	673 91 01
PA3XT20	PA3520	130-200 mm	87 505 44	673 91 02
PA3XT25	PA3525	130-200 mm	87 505 45	673 91 03
PA4XT10	PA4210	130-200 mm	87 505 46	673 91 04
PA4XT15	PA4215	130-200 mm	87 505 47	673 91 05
PA4XT20	PA4220	130-200 mm	87 505 48	673 91 06
PA4XT25	PA4225	130-200 mm	87 505 49	673 91 07

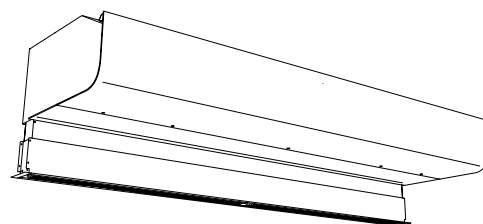
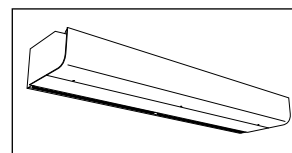
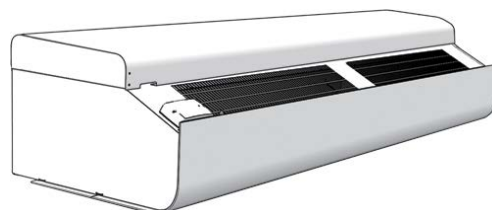

Fig. 10: See separate manual for PA3XT / PA4XT.

Type		Dimensions	E-nr (SE)	RSK-nr (SE)
PA3DW10	PA3510	87x382x1006 mm	87 505 77	673 91 27
PA3DW15	PA3515	87x382x1516 mm	87 505 78	673 91 28
PA3DW20	PA3520	87x382x2006 mm	87 505 79	673 91 29
PA3DW25	PA3525	87x382x2516 mm	87 505 80	673 91 30
PA4DW10	PA4210	87x424x1006 mm	87 505 81	673 91 31
PA4DW15	PA425	87x424x1516 mm	87 505 82	673 91 32
PA4DW20	PA4220	87x424x2006 mm	87 505 83	673 91 33
PA4DW25	PA4225	87x424x2516 mm	87 505 84	673 91 34



PA3DW
PA4DW



See separate manual for PA3DW/
PA4DW.

Type		Length	E-nr (SE)	RSK-nr (SE)
PA3DCS	PA3500	200-300 mm	87 505 60	673 91 08
PA3DCM	PA3500	300-500 mm	87 505 61	673 91 09
PA3DCL	PA3500	500-900 mm	87 505 62	673 91 10
PA3DXT	PA3500	420 mm	87 505 63	673 91 11
PA4DCS	PA4200	200-300 mm	87 505 64	673 91 12
PA4DCM	PA4200	300-500 mm	87 505 65	673 91 13
PA4DCL	PA4200	500-900 mm	87 505 66	673 91 14
PA4DXT	PA4200	420 mm	87 505 67	673 91 15



PA3DC
PA4DC

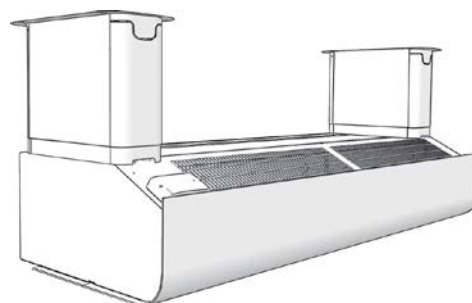

See separate manual for PA3DC /
PA4DC.

PA3510, PA4210: 2 pcs
 PA3515, PA4215: 2 pcs
 PA3520, PA4220: 3 pcs
 PA3525, PA4225: 4 pcs

Accessories

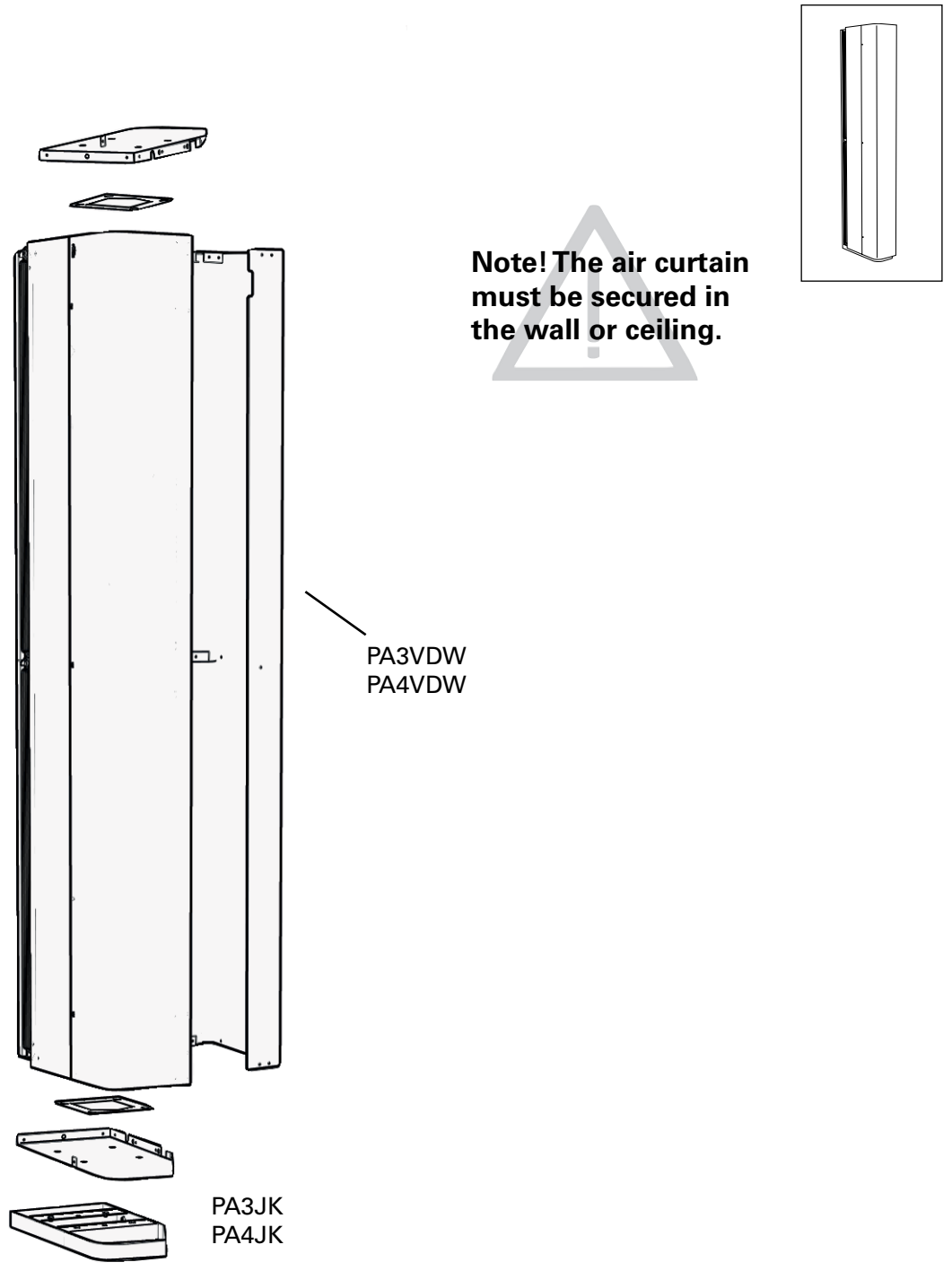
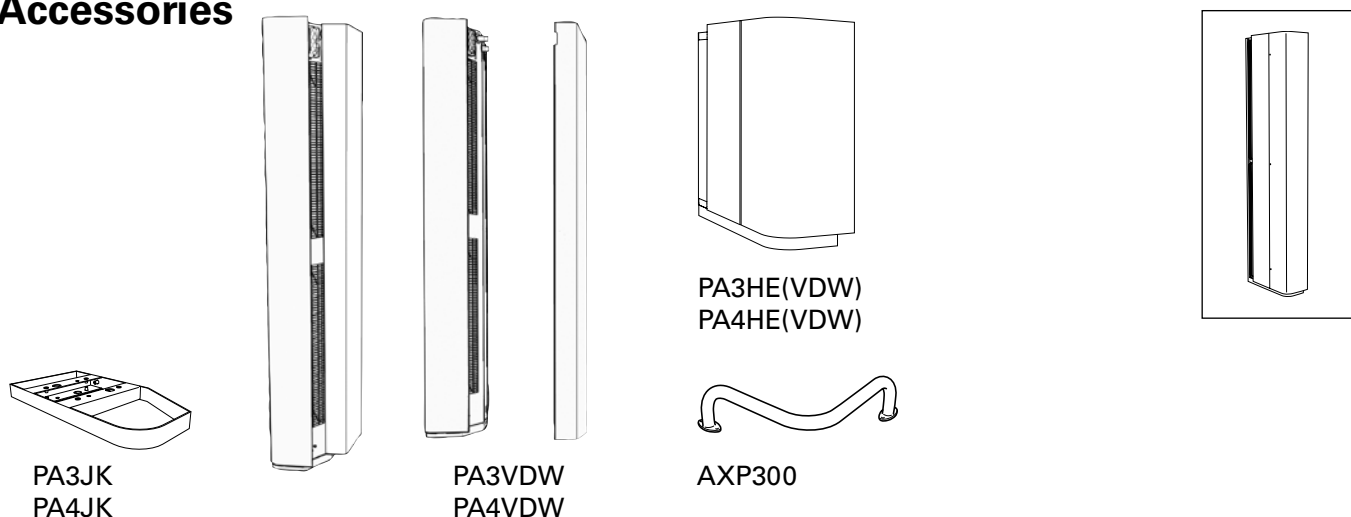
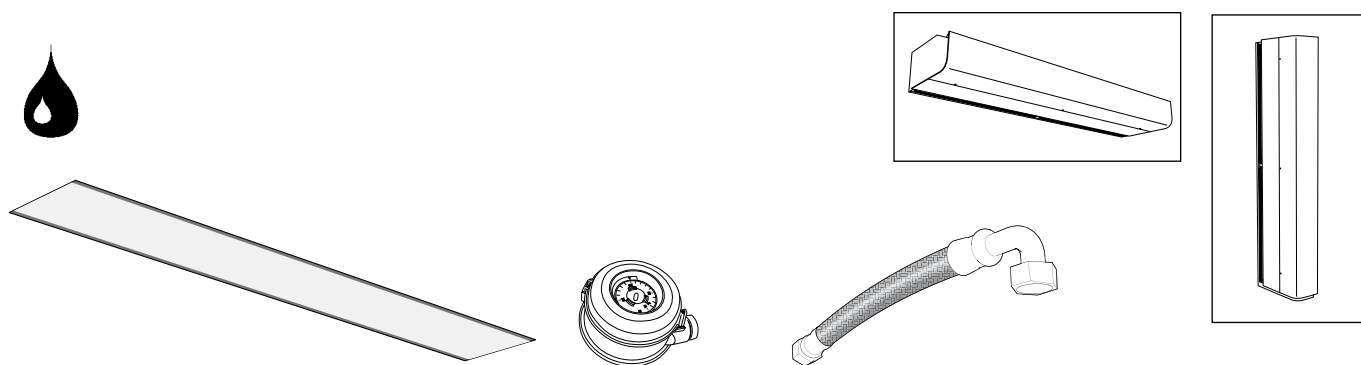

Fig. 11: See separate manual for PA3JK / PA4JK.

Accessories



Type		E-nr (SE)	RSK-nr (SE)	EL-nr (NO)	NRF-nr (NO)
PA3JK	PA3500	87 515 22	673 11 96	54 300 07	85 023 71
PA4JK	PA4200	87 515 23	673 11 97	54 300 08	85 023 72
PA3VDW15	PA3515	87 515 16	673 20 83	54 300 01	
PA3VDW20	PA3520	87 515 17	673 20 84	54 300 02	
PA3VDW25	PA3525	87 515 18	673 20 85	54 300 03	
PA4VDW15	PA4215	87 515 19	673 20 86	54 300 04	
PA4VDW20	PA4220	87 515 20	673 20 87	54 300 05	
PA4VDW25	PA4225	87 515 21	673 20 88	54 300 05	
PA3HE	PA3500				
PA4HE	PA4200				
PA3HEVDW	PA3500				
PA4HEVDW	PA4200				
AXP300	PA3500/4200	87 514 87	672 69 77		



See separate manual for PA34EF.

DTV200S

See separate manual for FHDN20.

Type		Length	RSK-nr (SE)
PA34EF10	PA3510W, PA4210W		673 20 95
PA34EF15	PA3515W, PA425W		673 20 96
PA34EF20	PA3520W, PA4220W		673 20 97
PA34EF25	PA3525W, PA4225W		673 20 98
DTV200S	PA3500/4200W		673 91 16
FHDN20	PA3500/4200W	350 mm	673 91 17
FHDN2010	PA3500/4200W	1000 mm	670 45 65

Accessories

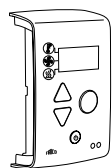

SIReBN

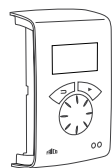
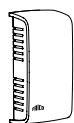
SIReACY
SIReAAY

SIReRTX

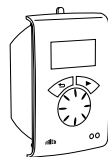

SIReUR

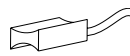

SIReWTA



SIReCJ4/SIReCJ6



SIReCC

Type	E-nr (SE)	RSK-nr (SE)	EL-nr (NO)	NRF-nr (NO)	Dimensions	Length
SIReBN	87 506 57	673 19 43	54 090 04	85 025 82		
SIReACY	87 506 61	673 21 00	54 090 08	85 025 85		
SIReAAY	87 506 62	673 24 06	54 090 09	85 025 86		
SIReRTX	87 510 12	673 09 22	54 910 01	85 022 94	70x33x23 mm	
SIReUR	87 510 11	673 09 21	49 325 00	85 022 93	114x70x50 mm	
SIReWTA		673 09 69				
SIReCJ4	87 510 33	673 09 70	54 910 02			
SIReCJ6	87 510 34	673 09 71		85 025 24		
SIReCC603	87 510 13	673 09 23	54 329 01	85 022 95		3 m
SIReCC605	87 510 14	673 09 24	54 329 02	85 022 96		5 m
SIReCC610	87 510 15	673 09 25	54 329 03	85 022 97		10 m
SIReCC615	87 510 16	673 09 26	54 329 04	85 022 98		15 m
SIReCC640	87 510 45	673 18 79				40 m
SIReCC403	87 510 17	673 09 27	54 329 05	85 022 99		3 m
SIReCC405	87 510 18	673 09 28	54 329 06	85 023 01		5 m
SIReCC410	87 510 19	673 09 29	54 329 07	85 023 02		10 m
SIReCC415	87 510 20	673 09 30	54 329 08	85 023 03		15 m



Type	RSK-nr (SE)	NRF-nr (NO)	Connection
VLSP15LF	670 45 35		DN15
VLSP15NF	670 45 36	85 026 36	DN15
VLSP20	670 45 37	85 026 37	DN20
VLSP25	670 45 38	85 026 38	DN25
VLSP32	670 45 39	85 026 39	DN32
VLP15LF	670 45 30	67 309 47	DN15
VLP15NF	670 45 31	85 026 31	DN15
VLP20	670 45 32	85 026 32	DN20
VLP25	670 45 33	85 026 33	DN25
VLP32	670 45 34	85 026 34	DN32
VOT15	673 61 93	85 024 05	DN15
VOT20	673 61 94	85 024 06	DN20
VOT25	673 61 95	85 024 07	DN25
VMT15			DN15
VMT20			DN20
VMT25			DN25

VLSP

VKF

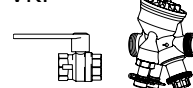

SD230



BPV10

VLP

VKF



SDM24



ST23024

VOT



TRVS



SD230

VMT



TRVS



SDM24



ST23024

PA3500 A
PA4200 A

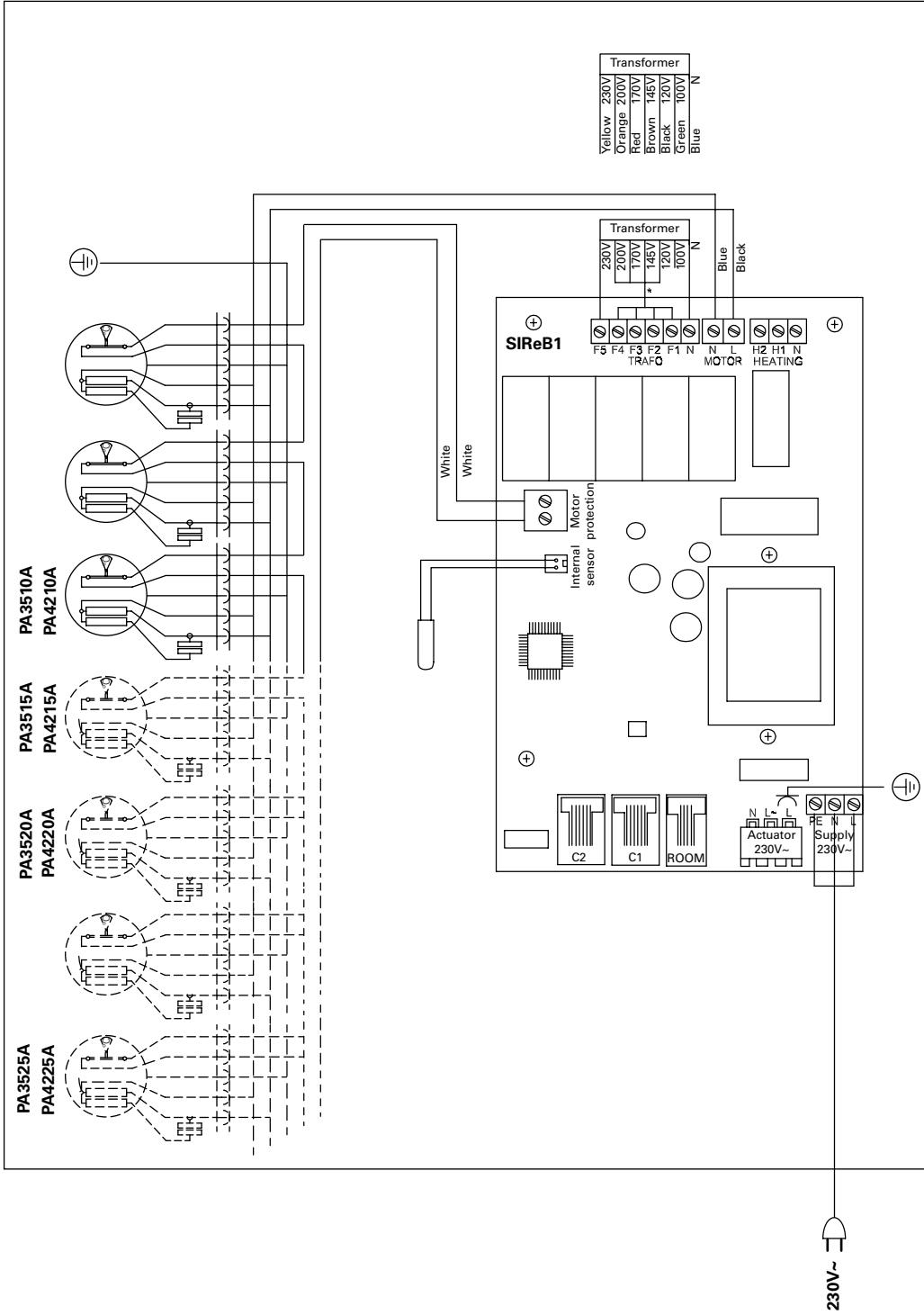

PA3500 E
PA4200 E

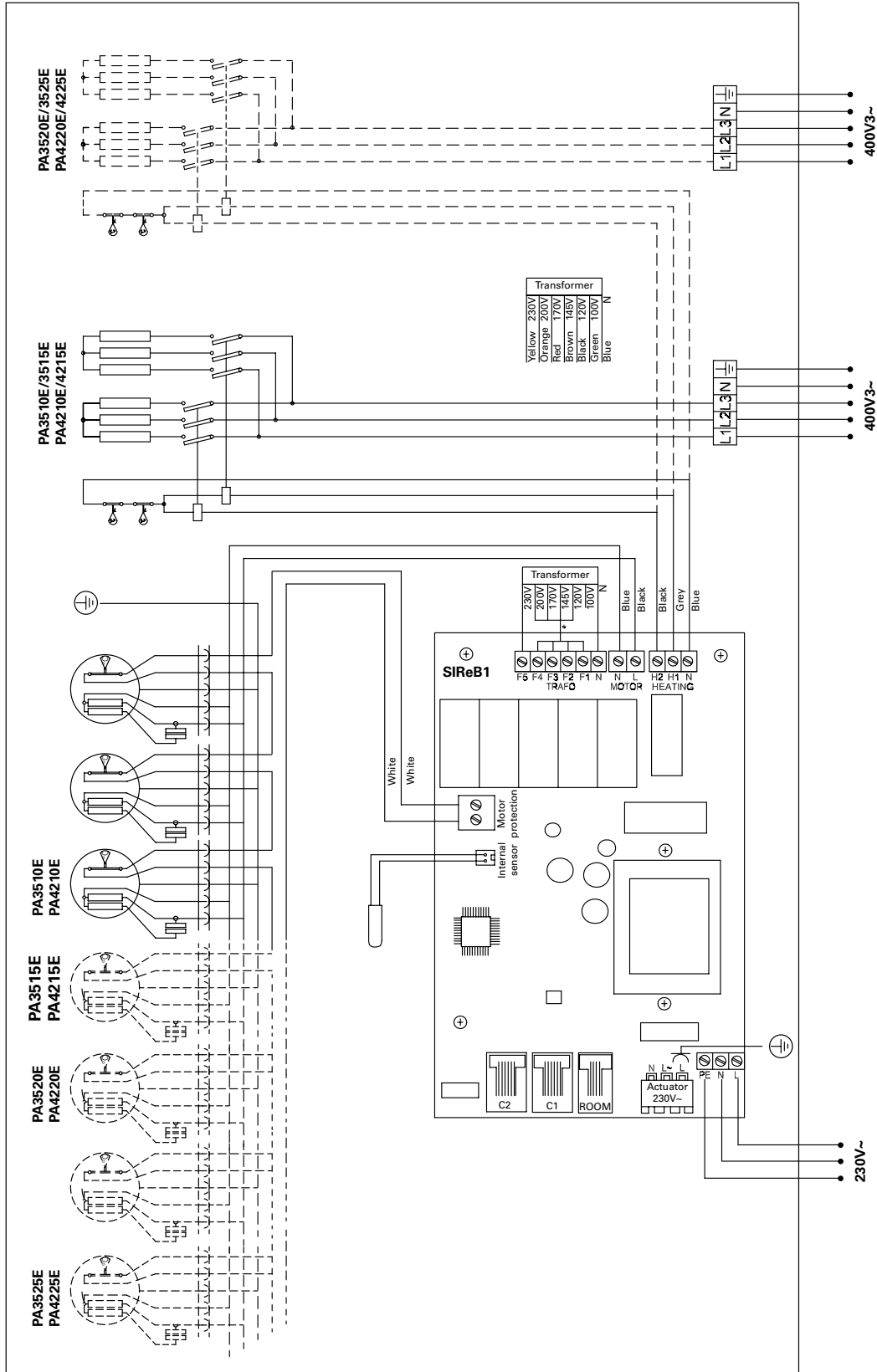

PA3500 W
PA4200 W

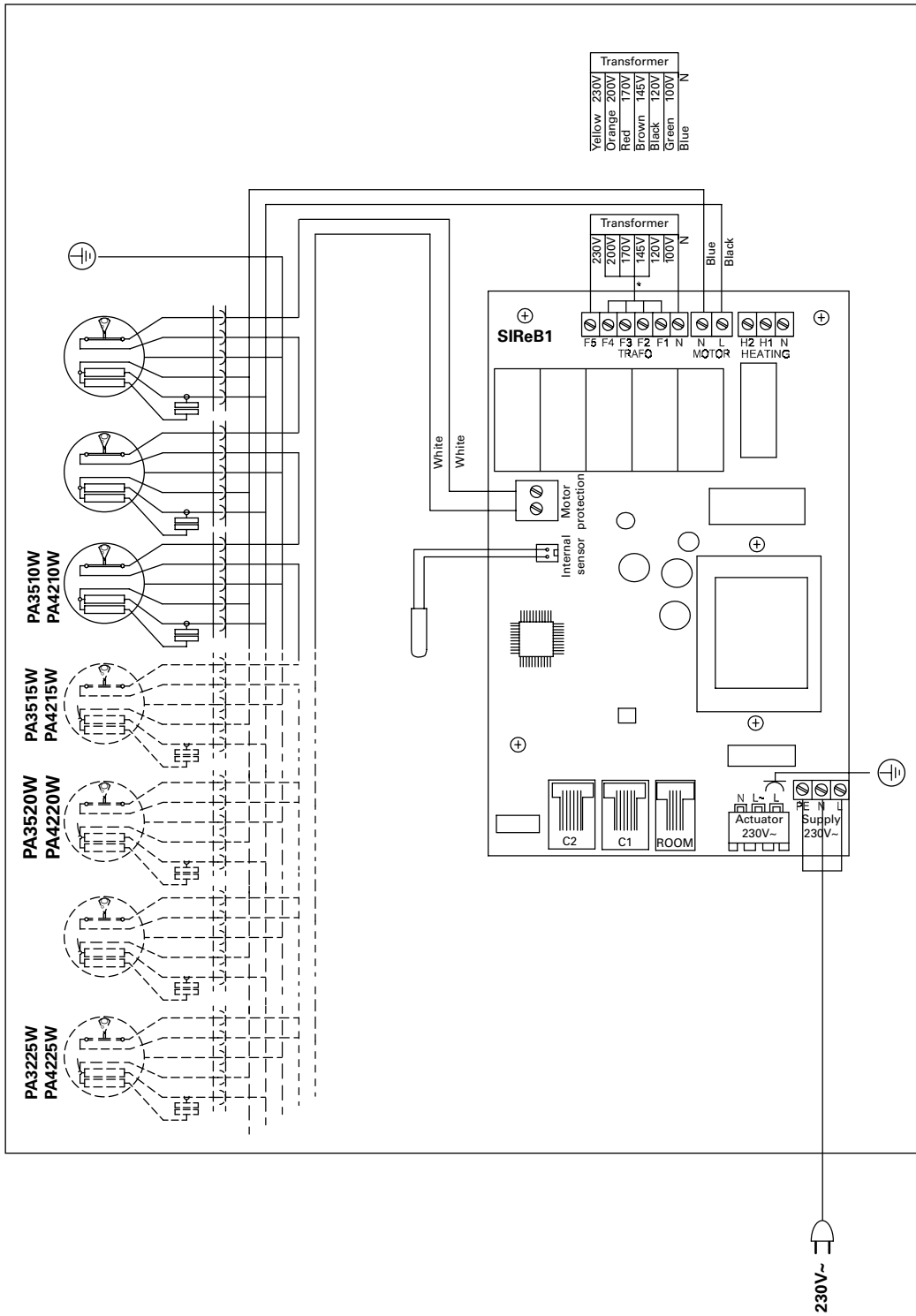

PA3500 E 230V3~
PA4200 E 230V3~

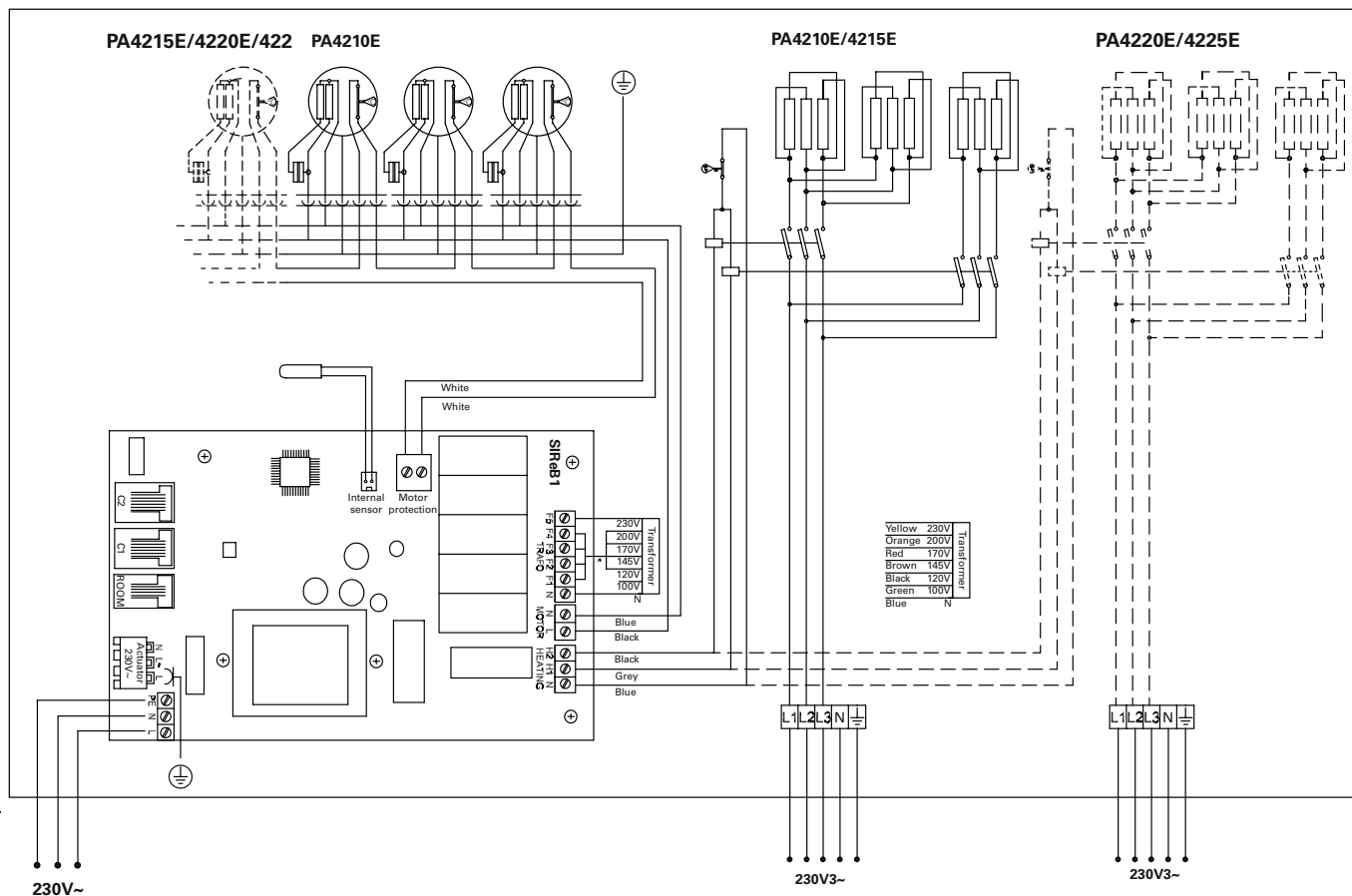

Type	Output step [kW]	Airflow*1 [m³/h]	Δt*3 [°C]	Sound level*2 [dB(A)]	Motor [W]	Voltage motor [V]	Amp. motor [A]	Voltage [V] Amperage [A] (heat)	Length [mm]	Weight [kg]
PA3510E08D	2,7/5,4/8,1	900/2000	27/12	41/61	580	230V~	2,6	230V3~/20,3	1039	44
PA3515E12D	3,9/7,8/12	1400/3100	26/12	42/62	880	230V~	3,9	230V3~/29,3	1549	63
PA3520E16D	5,4/11/16	1750/4000	28/12	43/63	1130	230V~	5,0	230V3~/40,5	2039	80
PA3525E20D	6,6/13/20	2400/5250	25/11,5	44/64	1500	230V~	6,5	230V3~/49,5	2549	104

Type	Output step [kW]	Airflow*1 [m³/h]	Δt*3 [°C]	Sound level*2 [dB(A)]	Motor [W]	Voltage motor [V]	Amp. motor [A]	Voltage [V] Amperage [A] (heat)	Length [mm]	Weight [kg]
PA4210E12D	3,9/7,8/12	950/2400	38/15	46/66	920	230V~	4,0	230V3~/30	1039	50
PA4215E18D	6,0/12/18	1300/3500	42/16	47/67	1260	230V~	5,5	230V3~/45	1549	71
PA4220E24D	7,8/15/23	1900/4800	37/14	48/68	1840	230V~	8,0	230V3~/60	2039	94
PA4225E30D	9,9/20/30	2300/5900	39/15	49/69	2140	230V~	9,3	230V3~/75	2549	113

*1) Lowest/highest airflow of totally 5 fan steps.

*2) Conditions: Distance to the unit 5 metres. Directional factor: 2. Equivalent absorption area: 200 m².

*3) Δt = temperature rise of passing air at maximum heat output and lowest/highest airflow.

Protection class for units with electrical heating: IP20.

CE compliant.

SIReB Basic

**PA3500/4200 A
PA3500/4200 E**

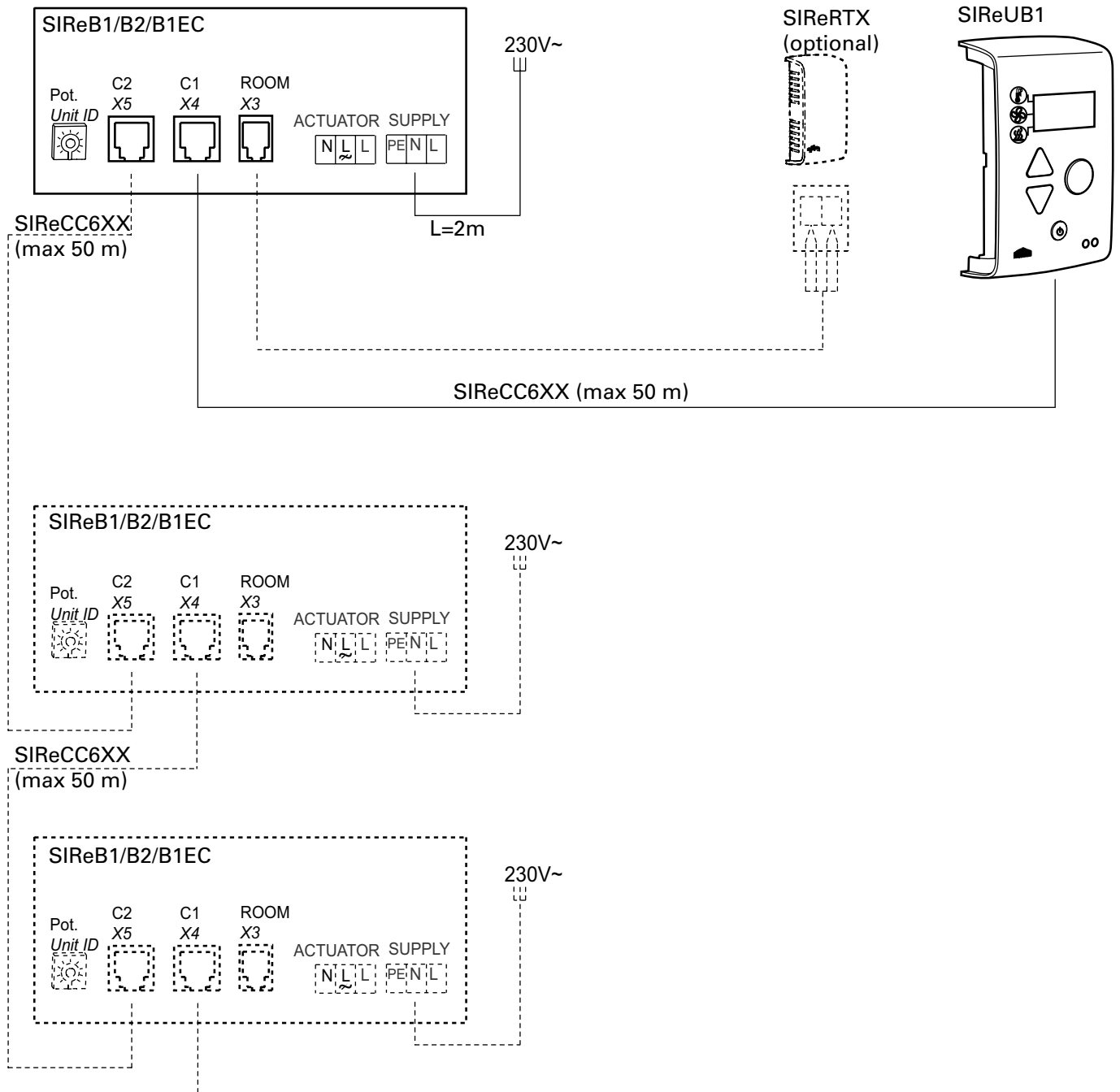

Wiring diagrams for SIReAC Competent, see manual for SIRe.

SIReB Basic

PA3500/4200 W

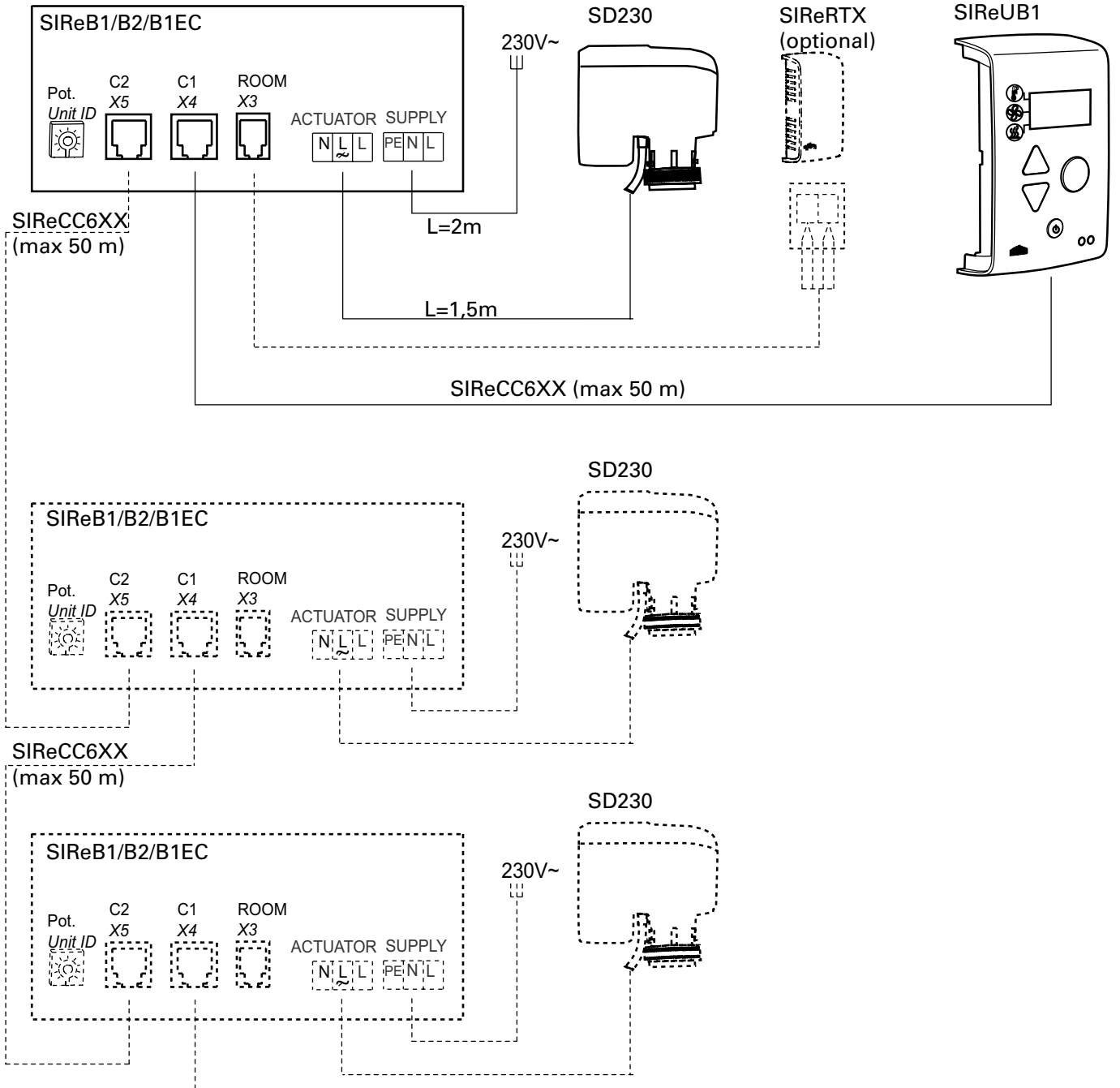

Wiring diagrams for SIReAC Competent and SIReAA Advanced, see manuals for SIRe.

Technical specifications PA3500

Voltage motor: 230V~

✦ Ambient, no heat - PA3500 A

Type	Output [kW]	Airflow* ¹ [m ³ /h]	Sound power* ² [dB(A)]	Sound pressure* ³ [dB(A)]	Motor [W]	Voltage motor [V]	Amperage motor [A]	Length [mm]	Weight [kg]
PA3510A	0	900/2000	78	41/61	580	230V~	2,6	1039	36
PA3515A	0	1400/3100	79	42/62	880	230V~	3,9	1549	50
PA3520A	0	1750/4000	79	43/63	1130	230V~	5,0	2039	65
PA3525A	0	2400/5250	80	44/64	1500	230V~	6,5	2549	79

ℓ Electrical heat - PA3500 E

Type	Output step [kW]	Airflow* ¹ [m ³ /h]	Δt * ⁴ [°C]	Sound power* ² [dB(A)]	Sound pressure* ³ [dB(A)]	Motor [W]	Amperage motor [A]	Voltage [V] Amperage [A] (heat)	Length [mm]	Weight [kg]
PA3510E08	2,7/5,4/8,1	900/2000	27/12	78	41/61	580	2,6	400V3~/11,7	1039	44
PA3515E12	3,9/7,8/12	1400/3100	26/12	79	42/62	880	3,9	400V3~/16,9	1549	63
PA3520E16	5,4/11/16	1750/4000	28/12	80	43/63	1130	5,0	400V3~/23,4	2039	80
PA3525E20	6,6/13/20	2400/5250	25/11,5	81	44/64	1500	6,5	400V3~/28,6	2549	104

♠ Water heat - PA3500 WL

Type	Output* ⁵ [kW]	Airflow* ¹ [m ³ /h]	Δt * ^{4,5} [°C]	Water volume [l]	Sound power* ² [dB(A)]	Sound pressure* ³ [dB(A)]	Motor [W]	Amperage motor [A]	Length [mm]	Weight [kg]
PA3510WL	12	950/1900	23/19	1,5	76	43/60	540	2,35	1039	43
PA3515WL	19	1350/2900	25/20	2,4	77	44/61	770	3,4	1549	60
PA3520WL	26	1800/3900	25/20	3,3	78	45/62	970	4,3	2039	75
PA3525WL	35	2300/5100	25/20	4,2	79	46/63	1310	5,7	2549	95

♠ Water heat - PA3500 WH

Type	Output* ⁶ [kW]	Airflow* ¹ [m ³ /h]	Δt * ^{4,6} [°C]	Water volume [l]	Sound power* ² [dB(A)]	Sound pressure* ³ [dB(A)]	Motor [W]	Amperage motor [A]	Length [mm]	Weight [kg]
PA3510WH	10	950/1900	21/16	1,0	76	43/60	540	2,35	1039	42
PA3515WH	16	1350/2900	22/17	1,6	77	44/61	770	3,4	1549	58
PA3520WH	23	1800/3900	23/17	2,2	78	45/62	970	4,3	2039	73
PA3525WH	29	2300/5100	23/17	2,9	79	46/63	1310	5,7	2549	92

♠ Water heat - PA3500 WLL

Type	Output* ⁷ [kW]	Airflow* ¹ [m ³ /h]	Δt * ^{4,7} [°C]	Water volume [l]	Sound power* ² [dB(A)]	Sound pressure* ³ [dB(A)]	Motor [W]	Amperage motor [A]	Length [mm]	Weight [kg]
PA3510WLL	7,6	900/1850	14/12	2,0	75	43/60	460	2,0	1039	44
PA3515WLL	11	1300/2750	14/12	4,1	76	44/61	740	3,25	1549	63
PA3520WLL	16	1700/3700	15/13	5,6	77	45/62	920	4,0	2039	78
PA3525WLL	21	2250/4900	15/13	8,3	78	46/63	1280	5,6	2549	100

*¹) Lowest/highest airflow of totally 5 fan steps.

*²) Sound power (L_{WA}) measurements according to ISO 27327-2: 2014, Installation type E.

*³) Sound pressure (L_{pA}). Conditions: Distance to the unit 5 metres. Directional factor: 2. Equivalent absorption area: 200 m². At lowest/highest airflow.

*⁴) Δt = temperature rise of passing air at maximum heat output and lowest/highest airflow.

*⁵) Applicable at water temperature 60/40 °C, air temperature, in +18 °C.

*⁶) Applicable at water temperature 80/60 °C, air temperature, in +18 °C.

*⁷) Applicable at water temperature 40/30 °C, air temperature, in +18 °C.

Protection class for units with electrical heating: IP20.

Protection class for units without heating and units with water heating: IP21.

CE compliant.

Technical specifications PA4200

Voltage motor: 230V~

✦ Ambient, no heat - PA4200 A

Type	Output [kW]	Airflow* ¹ [m ³ /h]	Sound power* ² [dB(A)]	Sound pressure* ³ [dB(A)]	Motor [W]	Voltage motor [V]	Amperage motor [A]	Length [mm]	Weight [kg]
PA4210A	0	950/2400	82	46/66	920	230V~	4,0	1039	43
PA4215A	0	1300/3500	83	47/67	1260	230V~	5,5	1549	56
PA4220A	0	1900/4800	84	48/68	1840	230V~	8,0	2039	75
PA4225A	0	2300/5900	85	49/69	2140	230V~	9,3	2549	91

⚡ Electrical heat - PA4200 E

Type	Output step [kW]	Airflow* ¹ [m ³ /h]	Δt * ⁴ [°C]	Sound power* ² [dB(A)]	Sound pressure* ³ [dB(A)]	Motor [W]	Amperage motor [A]	Voltage [V] Amperage [A] (heat)	Length [mm]	Weight [kg]
PA4210E12	3,9/7,8/12	950/2400	38/15	82	46/66	920	4,0	400V3~/16,9	1039	50
PA4215E18	6,0/12/18	1300/3500	42/16	83	47/67	1260	5,5	400V3~/26,0	1549	71
PA4220E24	7,8/15/23	1900/4800	37/14	84	48/68	1840	8,0	400V3~/33,8	2039	94
PA4225E30	9,9/20/30	2300/5900	39/15	85	49/69	2140	9,3	400V3~/42,9	2549	113

💧 Water heat - PA4200 WL

Type	Output* ⁵ [kW]	Airflow* ¹ [m ³ /h]	Δt * ^{4,5} [°C]	Water volume [l]	Sound power* ² [dB(A)]	Sound pressure* ³ [dB(A)]	Motor [W]	Amperage motor [A]	Length [mm]	Weight [kg]
PA4210WL	16	1050/2600	25/18	1,9	80	44/64	920	4,0	1039	50
PA4215WL	25	1600/3800	25/19	3,0	81	45/65	1330	5,8	1549	67
PA4220WL	35	2200/5300	25/19	4,1	82	46/66	1930	8,4	2039	90
PA4225WL	44	2800/6400	26/20	5,2	83	47/67	2280	9,9	2549	109

💧 Water heat - PA4200 WH

Type	Output* ⁶ [kW]	Airflow* ¹ [m ³ /h]	Δt * ^{4,6} [°C]	Water volume [l]	Sound power* ² [dB(A)]	Sound pressure* ³ [dB(A)]	Motor [W]	Amperage motor [A]	Length [mm]	Weight [kg]
PA4210WH	14	1050/2600	22/16	1,3	80	44/64	920	4,0	1039	49
PA4215WH	21	1600/3800	22/16	2,0	81	45/65	1330	5,8	1549	65
PA4220WH	30	2200/5300	23/17	2,7	82	46/66	1930	8,4	2039	87
PA4225WH	36	2800/6400	22/16	3,8	83	47/67	2280	9,9	2549	105

💧 Water heat - PA4200 WLL

Type	Output* ⁷ [kW]	Airflow* ¹ [m ³ /h]	Δt * ^{4,7} [°C]	Water volume [l]	Sound power* ² [dB(A)]	Sound pressure* ³ [dB(A)]	Motor [W]	Amperage motor [A]	Length [mm]	Weight [kg]
PA4210WLL	10	1000/2500	15/12	2,5	80	44/64	920	4,0	1039	52
PA4215WLL	15	1500/3600	15/13	4,7	81	45/65	1330	5,8	1549	70
PA4220WLL	21	2100/5200	15/12	7,5	82	46/66	1930	8,4	2039	95
PA4225WLL	26	2700/6200	15/12	9,6	83	47/67	2280	9,9	2549	115

*¹) Lowest/highest airflow of totally 5 fan steps.

*²) Sound power (L_{WA}) measurements according to ISO 27327-2: 2014, Installation type E.

*³) Sound pressure (L_{pA}). Conditions: Distance to the unit 5 metres. Directional factor: 2. Equivalent absorption area: 200 m². At lowest/highest airflow.

*⁴) Δt = temperature rise of passing air at maximum heat output and lowest/highest airflow.

*⁵) Applicable at water temperature 60/40 °C, air temperature, in +18 °C.

*⁶) Applicable at water temperature 80/60 °C, air temperature, in +18 °C.

*⁷) Applicable at water temperature 40/30 °C, air temperature, in +18 °C.

Protection class for units with electrical heating: IP20.

Protection class for units without heating and units with water heating: IP21.

CE compliant.

Output charts water PA3500 WH

			Supply water temperature: 110 °C Room temperature: +18 °C Outlet air temperature: +35 °C*1				Water temperature: 110/80 °C Room temperature: +18 °C			
Type	Fan position	Airflow [m³/h]	Output [kW]	Return water temp. [°C]	Water flow [l/s]	Pressure drop [kPA]	Output*2 [kW]	Outlet air temp. [°C]	Water flow [l/s]	Pressure drop [kPA]
PA3510WH	max	1900	11,1	53	0,05	1,9	15,8	42,4	0,13	10,8
	min	950	5,6	42	0,02	0,4	10,3	49,8	0,085	5
PA3515WH	max	2900	16,8	53	0,07	1	24,6	42,9	0,02	6,4
	min	1350	8	43	0,03	0,2	15,3	51,2	0,13	2,7
PA3520WH	max	3900	23	50	0,09	2	34,1	43,6	0,3	14
	min	1800	10,4	37	0,03	0,4	21	52,2	0,2	5,8
PA3525WH	max	5100	29,1	50	0,12	1,2	43,9	43,2	0,36	8,6
	min	2300	13,7	40	0,05	0,3	26,7	52	0,22	3,5
			Supply water temperature: 90 °C Room temperature: +18 °C Outlet air temperature: +35 °C*1				Water temperature: 90/70 °C Room temperature: +18 °C			
Type	Fan position	Airflow [m³/h]	Output [kW]	Return water temp. [°C]	Water flow [l/s]	Pressure drop [kPA]	Output*2 [kW]	Outlet air temp. [°C]	Water flow [l/s]	Pressure drop [kPA]
PA3510WH	max	1900	11,0	58	0,09	5,3	12,9	37,9	0,16	15,9
	min	950	5,5	45	0,03	0,9	8,4	43,8	0,1	7,3
PA3515WH	max	2900	16,9	58	0,13	3,1	20	38,2	0,25	9,4
	min	1350	7,9	45	0,04	0,4	12,4	44,9	0,15	4
PA3520WH	max	3900	22	54	0,15	4,8	27,7	38,8	0,34	20,6
	min	1800	10,2	41	0,05	0,7	17	45,7	0,21	8,5
PA3525WH	max	5100	30,3	58	0,24	4,2	35,7	38,5	0,44	12,6
	min	2300	13,4	43	0,07	0,5	21,6	45,6	0,27	5,1
			Supply water temperature: 80 °C Room temperature: +18 °C Outlet air temperature: +35 °C*1				Water temperature: 80/60 °C Room temperature: +18 °C			
Type	Fan position	Airflow [m³/h]	Output [kW]	Return water temp. [°C]	Water flow [l/s]	Pressure drop [kPA]	Output*2 [kW]	Outlet air temp. [°C]	Water flow [l/s]	Pressure drop [kPA]
PA3510WH	max	1900	10,8	61	0,14	13,3	10,6	34,3	0,13	11,4
	min	950	5,5	48	0,04	1,6	6,9	39,2	0,08	5,3
PA3515WH	max	2900	16,7	61	0,22	7,8	16,4	34,6	0,2	6,7
	min	1350	7,6	46	0,05	0,7	10,2	40,1	0,12	2,8
PA3520WH	max	3900	23,2	61	0,3	17,1	22,8	35,1	0,28	14,7
	min	1800	10,4	44	0,07	1,3	10,4	40,8	0,17	6,1
PA3525WH	max	5100	29,9	61	0,39	10,5	29,3	34,8	0,36	9
	min	2300	13,6	46	0,1	0,9	17,8	40,7	0,22	3,7
			Supply water temperature: 82 °C Room temperature: +18 °C Outlet air temperature: +35 °C*1				Water temperature: 82/71 °C Room temperature: +18 °C			
Type	Fan position	Airflow [m³/h]	Output [kW]	Return water temp. [°C]	Water flow [l/s]	Pressure drop [kPA]	Output*2 [kW]	Outlet air temp. [°C]	Water flow [l/s]	Pressure drop [kPA]
PA3510WH	max	1900	11,0	62,0	0,14	12,3	12,5	37,3	0,28	44,9
	min	950	5,4	46	0,04	1,2	8,1	43	0,18	20,5
PA3515WH	max	2900	17,1	62	0,21	7,2	19,5	37,7	0,43	27,1
	min	1350	7,7	46	0,05	0,6	12,1	44,2	0,27	11,2
PA3520WH	max	3900	22,4	58	0,23	10,3	26,8	38,2	0,6	58,5
	min	1800	10,6	44	0,07	1,2	16,5	44,8	0,37	23,9
PA3525WH	max	5100	28,7	58	0,3	6,3	34,6	37,9	0,78	35,9
	min	2300	13,1	44	0,08	0,7	21	44,7	0,47	14,3

*1) Recommended outlet air temperature for good comfort and optimized output.

*2) Nominal output at given supply and return water temperature.

See www.frico.se for additional calculations.

Output charts water PA3500 WL

			Supply water temperature: 80 °C Room temperature: +18 °C Outlet air temperature: +35 °C*1				Water temperature: 80/60 °C Room temperature: +18 °C			
Type	Fan position	Airflow [m³/h]	Output [kW]	Return water temp. [°C]	Water flow [l/s]	Pressure drop [kPA]	Output*2 [kW]	Outlet air temp. [°C]	Water flow [l/s]	Pressure drop [kPA]
PA3510WL	max	1900	11,3	33	0,06	1,5	21,1	50,6	0,26	20,4
	min	950	5,6	29	0,03	0,4	13	58,2	0,16	8,5
PA3515WL	max	2900	16,9	30	0,08	1,9	33,5	51,9	0,4	32,8
	min	1350	8	27	0,04	0,5	19,4	60,2	0,24	12,2
PA3520WL	max	3900	23,2	31	0,11	1,4	45,3	52	0,55	22,8
	min	1800	10,6	28	0,05	0,3	26	60,3	0,32	8,4
PA3525WL	max	5100	30	29	0,14	2,5	59,7	52,3	0,73	45
	min	2300	13,2	25	0,06	0,5	33,7	60,9	0,41	15,9

			Supply water temperature: 70 °C Room temperature: +18 °C Outlet air temperature: +35 °C*1				Water temperature: 70/50 °C Room temperature: +18 °C			
Type	Fan position	Airflow [m³/h]	Output [kW]	Return water temp. [°C]	Water flow [l/s]	Pressure drop [kPA]	Output*2 [kW]	Outlet air temp. [°C]	Water flow [l/s]	Pressure drop [kPA]
PA3510WL	max	1900	11,3	35	0,08	2,5	16,7	43,7	0,2	13,6
	min	950	5,5	30	0,03	0,6	10,3	49,8	0,13	5,8
PA3515WL	max	2900	16,6	32	0,1	3	26,6	44,9	0,32	22
	min	1350	7,8	28	0,05	0,7	15,5	51,6	0,19	8,3
PA3520WL	max	3900	22	32	0,14	2,1	35,8	44,9	0,44	15,3
	min	1800	10,5	28	0,06	0,5	20,7	51,7	0,25	5,7
PA3525WL	max	5100	29,5	31	0,18	4	47,4	45,3	0,58	30,3
	min	2300	13,2	26	0,07	0,8	26,9	52,3	0,33	11

			Supply water temperature: 60 °C Room temperature: +18 °C Outlet air temperature: +35 °C*1				Water temperature: 60/40 °C Room temperature: +18 °C			
Type	Fan position	Airflow [m³/h]	Output [kW]	Return water temp. [°C]	Water flow [l/s]	Pressure drop [kPA]	Output*2 [kW]	Outlet air temp. [°C]	Water flow [l/s]	Pressure drop [kPA]
PA3510WL	max	1900	11,2	37	0,12	5,6	12,1	36,7	0,15	7,9
	min	950	5,5	31	0,05	1,1	7,6	41,3	0,09	3,4
PA3515WL	max	2900	16,8	35	0,16	6,6	19,5	37,7	0,24	13
	min	1350	8	30	0,06	1,3	11,5	42,9	0,14	5
PA3520WL	max	3900	22,4	35	0,22	4,5	26,2	37,7	0,32	9
	min	1800	10,3	30	0,08	0,8	15,3	42,9	0,19	3,4
PA3525WL	max	5100	30,4	35	0,29	9,3	35	38,1	0,42	18,1
	min	2300	13,5	28	0,1	1,5	20	43,5	0,24	6,7

			Supply water temperature: 55 °C Room temperature: +18 °C Outlet air temperature: +35 °C*1				Water temperature: 55/35 °C Room temperature: +18 °C			
Type	Fan position	Airflow [m³/h]	Output [kW]	Return water temp. [°C]	Water flow [l/s]	Pressure drop [kPA]	Output*2 [kW]	Outlet air temp. [°C]	Water flow [l/s]	Pressure drop [kPA]
PA3510WL	max	1900	11,2	39	0,18	10,7	9,8	33,1	0,12	5,5
	min	950	5,5	32	0,06	1,7	6,1	36,8	0,07	2,4
PA3515WL	max	2900	16,9	37	0,23	12,3	15,9	34,1	0,19	9,1
	min	1350	7,8	30	0,08	1,8	9,4	38,3	0,11	3,6
PA3520WL	max	3900	22,7	37	0,3	8,5	21,3	34	0,26	6,3
	min	1800	10,2	30	0,1	1,2	12,4	38,3	0,15	2,4
PA3525WL	max	5100	30,4	37	0,4	17,2	28,7	34,5	0,35	12,8
	min	2300	13,2	29	0,12	2,1	16,5	39	0,2	4,8

*1) Recommended outlet air temperature for good comfort and optimized output.

*2) Nominal output at given supply and return water temperature.

See www.frico.se for additional calculations.

Output charts water PA3500 WLL

			Supply water temperature: 55 °C Room temperature: +18 °C Outlet air temperature: +32 °C				Water temperature: 55/35 °C Room temperature: +18 °C			
Type	Fan position	Airflow [m³/h]	Output [kW]	Return water temp. [°C]	Water flow [l/s]	Pressure drop [kPA]	Output* [kW]	Outlet air temp. [°C]	Water flow [l/s]	Pressure drop [kPA]
PA3510WLL	max	1850	8,9	29,0	0,08	1,7	11,8	36,7	0,08	1,7
	min	900	4,4	28	0,04	0,5	6,9	40,5	0,04	0,5
PA3515WLL	max	2750	13,5	30	0,13	1	17,4	36,5	0,21	2,2
	min	1300	5,8	31	0,06	0,2	9,7	40,1	0,18	0,8
PA3520WLL	max	3700	17,7	27	0,16	1,6	17,7	38	0,3	5,1
	min	1700	8,2	27	0,07	0,4	8,2	42	0,17	1,8
PA3525WLL	max	4900	23,5	28	0,21	1,6	32,7	37,6	0,4	4,8
	min	2250	11	28	0,1	0,4	18,1	41,6	0,22	1,7

			Supply water temperature: 50 °C Room temperature: +18 °C Outlet air temperature: +32 °C				Water temperature: 50/30 °C Room temperature: +18 °C			
Type	Fan position	Airflow [m³/h]	Output [kW]	Return water temp. [°C]	Water flow [l/s]	Pressure drop [kPA]	Output* [kW]	Outlet air temp. [°C]	Water flow [l/s]	Pressure drop [kPA]
PA3510WLL	max	1850	9,0	30	0,11	2,7	8,9	32	0,11	2,6
	min	900	4,3	28	0,05	0,6	5,1	34,7	0,06	1
PA3515WLL	max	2750	12,9	30	0,16	1,3	12,7	31,5	0,15	1,3
	min	1300	6,2	30	0,07	0,4	6,5	32,8	0,08	0,4
PA3520WLL	max	3700	17,6	28	0,2	2,4	19,2	33,2	0,23	3,2
	min	1700	8,4	27	0,09	0,6	10,6	36,2	0,13	1,2
PA3525WLL	max	4900	22,6	28	0,25	2,2	24,8	32,8	0,3	3
	min	2250	10,9	27	0,12	0,6	13,6	35,8	0,16	1

			Supply water temperature: 45 °C Room temperature: +18 °C Outlet air temperature: +32 °C				Water temperature: 45/35 °C Room temperature: +18 °C			
Type	Fan position	Airflow [m³/h]	Output [kW]	Return water temp. [°C]	Water flow [l/s]	Pressure drop [kPA]	Output* [kW]	Outlet air temp. [°C]	Water flow [l/s]	Pressure drop [kPA]
PA3510WLL	max	1850	9,1	32,0	0,17	5,9	10,2	34,2	0,25	11,4
	min	900	4,4	29	0,07	1,2	5,9	37,2	0,14	4,4
PA3515WLL	max	2750	13,5	32	0,25	3	15,4	34,4	0,37	6
	min	1300	6,3	30	0,1	0,6	8,5	37,5	0,2	2,1
PA3520WLL	max	3700	18,1	30	0,3	5,1	21,6	35,1	0,52	13,6
	min	1700	8,1	27	0,11	0,9	11,8	38,3	0,29	4,7
PA3525WLL	max	4900	23,4	30	0,39	4,7	28,2	34,9	0,68	12,8
	min	2250	11,1	28	0,16	1	15,4	38,1	0,37	4,4

			Supply water temperature: 40 °C Room temperature: +18 °C Outlet air temperature: +32 °C				Water temperature: 40/30 °C Room temperature: +18 °C			
Type	Fan position	Airflow [m³/h]	Output [kW]	Return water temp. [°C]	Water flow [l/s]	Pressure drop [kPA]	Output* [kW]	Outlet air temp. [°C]	Water flow [l/s]	Pressure drop [kPA]
PA3510WLL	max	1850	8,9	34	0,35	21,0	7,6	30	0,18	6,9
	min	900	4,4	30	0,11	2,7	4,4	32,4	0,11	2,7
PA3515WLL	max	2750	12,8	32	0,41	7,4	11,3	30	0,27	3,5
	min	1300	6,2	30	0,15	1,2	6,2	32,2	0,15	1,2
PA3520WLL	max	3700	17,9	32	0,58	16,6	16,1	30,8	0,39	8,3
	min	1700	8,3	29	0,18	2,1	8,9	33,3	0,21	2,9
PA3525WLL	max	4900	23,4	32	0,75	15,6	21	30,6	0,51	7,7
	min	2250	10,7	29	0,23	1,9	11,6	33,1	0,28	2,7

*1) Recommended outlet air temperature for good comfort and optimized output.

*2) Nominal output at given supply and return water temperature.

See www.frico.se for additional calculations.

Output charts water PA4200 WH

			Supply water temperature: 110 °C Room temperature: +18 °C Outlet air temperature: +35 °C*1				Water temperature: 110/80 °C Room temperature: +18 °C			
Type	Fan position	Airflow [m³/h]	Output [kW]	Return water temp. [°C]	Water flow [l/s]	Pressure drop [kPA]	Output*2 [kW]	Outlet air temp. [°C]	Water flow [l/s]	Pressure drop [kPA]
PA4210WH	max	2600	15,1	53	0,06	3,9	21,2	41,9	0,17	22,1
	min	1050	6,1	37	0,02	0,5	12,1	51,6	0,10	8
PA4215WH	max	3800	21,7	53	0,09	1,2	31,7	42,4	0,26	7,6
	min	1600	9,1	42	0,03	0,2	18,5	51,8	0,15	2,8
PA4220WH	max	5300	30,2	50	0,12	2,4	44,9	42,8	0,37	17,1
	min	2200	12,7	37	0,04	0,4	25,9	52,5	0,21	6,3
PA4225WH	max	6400	36,2	53	0,16	0,6	54	42,7	0,44	4
	min	2800	16,3	44	0,06	0,1	32,2	51,7	0,27	1,6
			Supply water temperature: 90 °C Room temperature: +18 °C Outlet air temperature: +35 °C*1				Water temperature: 90/70 °C Room temperature: +18 °C			
Type	Fan position	Airflow [m³/h]	Output [kW]	Return water temp. [°C]	Water flow [l/s]	Pressure drop [kPA]	Output*2 [kW]	Outlet air temp. [°C]	Water flow [l/s]	Pressure drop [kPA]
PA4210WH	max	2600	14,7	58	0,11	11,0	17,2	37,4	0,21	32,4
	min	1050	6,0	41	0,03	1,1	9,8	45,3	0,12	11,7
PA4215WH	max	3800	21,7	58	0,17	3,6	25,7	37,9	0,32	11,3
	min	1600	9,5	45	0,05	0,4	15	45,4	0,18	4,2
PA4220WH	max	5300	31,1	58	0,24	8,3	36,4	38,1	0,45	25,1
	min	2200	12,6	41	0,06	0,8	21	45,9	0,26	9,2
PA4225WH	max	6400	36,8	58	0,29	1,9	43,9	38,1	0,54	6
	min	2800	15,9	45	0,09	0,2	26,1	45,4	0,32	2,3
			Supply water temperature: 80 °C Room temperature: +18 °C Outlet air temperature: +35 °C*1				Water temperature: 80/60 °C Room temperature: +18 °C			
Type	Fan position	Airflow [m³/h]	Output [kW]	Return water temp. [°C]	Water flow [l/s]	Pressure drop [kPA]	Output*2 [kW]	Outlet air temp. [°C]	Water flow [l/s]	Pressure drop [kPA]
PA4210WH	max	2600	15,2	65	0,25	44,5	14,2	34	0,17	23,4
	min	1050	6,0	44	0,04	1,9	8,1	40,5	0,10	8,5
PA4215WH	max	3800	21,5	61	0,28	9,3	21,1	34,3	0,26	8
	min	1600	9,2	46	0,07	0,7	12,3	40,5	0,15	3
PA4220WH	max	5300	30,5	61	0,40	20,9	30	34,6	0,37	18
	min	2200	12,8	44	0,09	1,4	17,3	41	0,21	6,6
PA4225WH	max	6400	36,7	61	0,48	4,9	35,9	34,4	0,44	4,2
	min	2800	16,6	48	0,13	0,5	21,4	40,4	0,26	1,7
			Supply water temperature: 82 °C Room temperature: +18 °C Outlet air temperature: +35 °C*1				Water temperature: 82/71 °C Room temperature: +18 °C			
Type	Fan position	Airflow [m³/h]	Output [kW]	Return water temp. [°C]	Water flow [l/s]	Pressure drop [kPA]	Output*2 [kW]	Outlet air temp. [°C]	Water flow [l/s]	Pressure drop [kPA]
PA4210WH	max	2600	14,8	62	0,18	25,1	16,6	36,7	0,37	91,4
	min	1050	6,1	44	0,04	1,8	9,4	44,3	0,21	32,5
PA4215WH	max	3800	22,0	62	0,27	8,6	25,1	37,4	0,56	32,5
	min	1600	9,3	46	0,06	0,7	14,6	44,7	0,32	11,9
PA4220WH	max	5300	31,3	62	0,38	19,3	35,3	37,5	0,79	71,9
	min	2200	12,4	42	0,08	1,1	20,3	45	0,45	25,9
PA4225WH	max	6400	37,5	62	0,46	4,5	42,9	37,7	0,96	17,2
	min	2800	15,8	46	0,11	0,4	25,5	44,7	0,57	6,6

*1) Recommended outlet air temperature for good comfort and optimized output.

*2) Nominal output at given supply and return water temperature.

See www.frico.se for additional calculations.

Output charts water PA4200 WL

			Supply water temperature: 80 °C Room temperature: +18 °C Outlet air temperature: +35 °C*1				Water temperature: 80/60 °C Room temperature: +18 °C			
Type	Fan position	Airflow [m³/h]	Output [kW]	Return water temp. [°C]	Water flow [l/s]	Pressure drop [kPA]	Output*2 [kW]	Outlet air temp. [°C]	Water flow [l/s]	Pressure drop [kPA]
PA4210WL	max	2600	14,9	31	0,07	2,7	28,4	50	0,35	42
	min	1050	6,0	26	0,03	0,5	15	59,9	0,18	13,3
PA4215WL	max	3800	21,7	30	0,11	2,2	43,3	51,4	0,53	38,4
	min	1600	9,5	27	0,04	0,5	23,3	60,7	0,29	12,5
PA4220WL	max	5300	31,4	31	0,15	2,0	60,1	51,2	0,73	31,9
	min	2200	12,8	27	0,06	0,4	32,1	60,7	0,39	10,2
PA4225WL	max	6400	36,6	28	0,17	2,9	75	52,3	0,92	56,7
	min	2800	16,3	24	0,07	0,6	41,4	61,3	0,51	19,2
			Supply water temperature: 70 °C Room temperature: +18 °C Outlet air temperature: +35 °C*1				Water temperature: 70/50 °C Room temperature: +18 °C			
Type	Fan position	Airflow [m³/h]	Output [kW]	Return water temp. [°C]	Water flow [l/s]	Pressure drop [kPA]	Output*2 [kW]	Outlet air temp. [°C]	Water flow [l/s]	Pressure drop [kPA]
PA4210WL	max	2600	14,9	33	0,10	4,6	22,5	43,4	0,27	28,2
	min	1050	6,1	28	0,03	0,8	12	51,4	0,15	9,1
PA4215WL	max	3800	22,1	32	0,14	3,8	34,3	44,4	0,42	25,7
	min	1600	9,4	28	0,05	0,7	18,6	52,1	0,23	8,5
PA4220WL	max	5300	31,4	33	0,21	3,5	47,6	44,3	0,58	21,4
	min	2200	12,7	28	0,07	0,6	25,6	52,1	0,31	7
PA4225WL	max	6400	36,4	30	0,22	4,7	59,7	45,3	0,73	38,3
	min	2800	15,8	25	0,09	0,9	33,1	52,7	0,40	13,2
			Supply water temperature: 60 °C Room temperature: +18 °C Outlet air temperature: +35 °C*1				Water temperature: 60/40 °C Room temperature: +18 °C			
Type	Fan position	Airflow [m³/h]	Output [kW]	Return water temp. [°C]	Water flow [l/s]	Pressure drop [kPA]	Output*2 [kW]	Outlet air temp. [°C]	Water flow [l/s]	Pressure drop [kPA]
PA4210WL	max	2600	15,4	37	0,17	11,8	16,5	36,6	0,20	16,6
	min	1050	6,2	30	0,05	1,4	8,9	42,7	0,11	5,5
PA4215WL	max	3800	21,6	35	0,21	7,6	25,2	37,4	0,31	15
	min	1600	9,2	29	0,07	1,2	13,8	43,2	0,17	5,1
PA4220WL	max	5300	29,9	35	0,29	6,3	34,9	37,3	0,42	12,6
	min	2200	13,1	30	0,10	1,1	18,9	43,2	0,23	4,2
PA4225WL	max	6400	36,8	33	0,34	10,0	44,1	38,2	0,54	22,8
	min	2800	16,3	28	0,12	1,7	24,7	43,9	0,30	8,1
			Supply water temperature: 55 °C Room temperature: +18 °C Outlet air temperature: +35 °C*1				Water temperature: 55/35 °C Room temperature: +18 °C			
Type	Fan position	Airflow [m³/h]	Output [kW]	Return water temp. [°C]	Water flow [l/s]	Pressure drop [kPA]	Output*2 [kW]	Outlet air temp. [°C]	Water flow [l/s]	Pressure drop [kPA]
PA4210WL	max	2600	15,2	39	0,23	22,3	13,4	33,1	0,16	11,7
	min	1050	6,0	30	0,06	2,0	7,2	38,2	0,09	3,9
PA4215WL	max	3800	21,8	37	0,29	14,2	20,5	33,8	0,25	10,5
	min	1600	9,3	30	0,09	1,8	11,3	38,6	0,14	3,6
PA4220WL	max	5300	30,2	37	0,41	11,9	28,4	33,7	0,34	8,8
	min	2200	12,8	30	0,13	1,5	15,5	38,6	0,19	3
PA4225WL	max	6400	37,1	36	0,47	18,4	36,2	34,6	0,44	16,2
	min	2800	16,5	29	0,15	2,6	20,4	39,3	0,25	5,8

*1) Recommended outlet air temperature for good comfort and optimized output.

*2) Nominal output at given supply and return water temperature.

See www.frico.se for additional calculations.

Output charts water PA4200 WLL

			Supply water temperature: 55 °C Room temperature: +18 °C Outlet air temperature: +32 °C				Water temperature: 55/35 °C Room temperature: +18 °C			
Type	Fan position	Airflow [m³/h]	Output [kW]	Return water temp. [°C]	Water flow [l/s]	Pressure drop [kPA]	Output* [kW]	Outlet air temp. [°C]	Water flow [l/s]	Pressure drop [kPA]
PA4210WLL	max	2500	12,0	29	0,11	2,0	15,7	36,5	0,19	4,9
	min	1000	4,8	28	0,04	0,4	7,9	41,3	0,10	1,5
PA4215WLL	max	3600	17,2	27	0,15	2,0	24,3	37,8	0,29	6,4
	min	1500	7,4	27	0,06	0,5	12,5	42,4	0,15	2
PA4220WLL	max	5200	25,1	29	0,23	1,6	33,3	36,8	0,40	4,2
	min	2100	9,0	29	0,08	0,3	16,7	41,3	0,20	1,2
PA4225WLL	max	6200	29,5	28	0,26	1,7	41,3	37,5	0,50	5,3
	min	2700	13,9	28	0,13	0,5	21,9	41,8	0,27	1,7
			Supply water temperature: 50 °C Room temperature: +18 °C Outlet air temperature: +32 °C				Water temperature: 50/30 °C Room temperature: +18 °C			
Type	Fan position	Airflow [m³/h]	Output [kW]	Return water temp. [°C]	Water flow [l/s]	Pressure drop [kPA]	Output* [kW]	Outlet air temp. [°C]	Water flow [l/s]	Pressure drop [kPA]
PA4210WLL	max	2500	12,0	30	0,15	3,2	11,9	31,9	0,14	3,1
	min	1000	4,9	28	0,05	0,6	5,9	35,3	0,07	0,9
PA4215WLL	max	3600	17,0	28	0,19	3,1	18,6	33,1	0,22	4,1
	min	1500	7,2	26	0,07	0,6	9,5	36,6	0,12	1,3
PA4220WLL	max	5200	25,3	30	0,31	2,7	24,9	32,1	0,30	2,6
	min	2100	10,0	28	0,11	0,5	12,2	35	0,15	0,7
PA4225WLL	max	6200	30,1	29	0,35	2,9	31,3	32,8	0,38	3,3
	min	2700	12,8	27	0,14	0,6	16,4	35,8	0,20	1
			Supply water temperature: 45 °C Room temperature: +18 °C Outlet air temperature: +32 °C				Water temperature: 45/35 °C Room temperature: +18 °C			
Type	Fan position	Airflow [m³/h]	Output [kW]	Return water temp. [°C]	Water flow [l/s]	Pressure drop [kPA]	Output* [kW]	Outlet air temp. [°C]	Water flow [l/s]	Pressure drop [kPA]
PA4210WLL	max	2500	12,2	32	0,23	6,9	13,7	34	0,33	13,4
	min	1000	4,8	28	0,07	0,9	6,8	37,9	0,16	3,9
PA4215WLL	max	3600	17,4	30	0,29	6,4	20,8	34,9	0,50	17
	min	1500	7,3	27	0,10	1,0	10,5	38,5	0,25	5,1
PA4220WLL	max	5200	25,7	32	0,48	5,8	29	34,3	0,70	11,5
	min	2100	10,1	28	0,15	0,7	14,4	38,1	0,35	3,3
PA4225WLL	max	6200	29,6	30	0,49	5,2	35,6	34,8	0,86	14,4
	min	2700	13,3	28	0,19	1,0	18,7	38,3	0,45	4,5
			Supply water temperature: 40 °C Room temperature: +18 °C Outlet air temperature: +32 °C				Water temperature: 40/30 °C Room temperature: +18 °C			
Type	Fan position	Airflow [m³/h]	Output [kW]	Return water temp. [°C]	Water flow [l/s]	Pressure drop [kPA]	Output* [kW]	Outlet air temp. [°C]	Water flow [l/s]	Pressure drop [kPA]
PA4210WLL	max	2500	11,9	34,0	0,46	24,6	10,1	29,9	0,24	8
	min	1000	4,7	29,0	0,10	1,7	5,1	32,8	0,12	2,4
PA4215WLL	max	3600	17,2	32,0	0,55	20,7	15,5	30,6	0,37	10,4
	min	1500	7,4	29,0	0,16	2,3	7,9	33,5	0,19	3,2
PA4220WLL	max	5200	24,1	32,0	0,77	14,1	21,4	30,1	0,52	6,8
	min	2100	9,8	29,0	0,21	1,4	10,7	32,9	0,26	2
PA4225WLL	max	6200	29,6	32,0	0,95	17,6	26,5	30,5	0,64	8,6
	min	2700	13,0	29,0	0,28	1,9	14	33,2	0,34	2,7

*1) Recommended outlet air temperature for good comfort and optimized output.

*2) Nominal output at given supply and return water temperature.

See www.frico.se for additional calculations.

Installation and operating instructions

General Instructions

Read these instructions carefully before installation and use. Keep this manual for future reference.

The product may only be used as set out in the assembly and operating instructions. The guarantee is only valid if the product is used in the manner intended and in accordance with the instructions.

Application area

PA3500 is intended for entrances and smaller doors up to 3.5 metres in height.

PA4200 is intended for larger door ways and industrial door up to 4.2 metres in height.

The air curtain is available without heat, with electrical heating and with water heating.

Protection class for units with electrical heating: IP20.

Protection class for units without heating and units with water heating: IP21.

Operation

Air is drawn in at the top/rear of the unit and blown out downwards/outwards so that it shields the door opening and minimizes heat loss. To achieve the optimum air curtain effect the unit must extend the full height/width of the door opening.

The grille for directing exhaust air is adjustable and is normally angled outwards to achieve the best protection against incoming air.

The efficiency of the air curtain depends on the air temperature, pressure differences across the doorway and any wind pressure.

NOTE! Negative pressure in the building considerably reduces the efficiency of the air curtain. The ventilation should therefore be balanced.

Mounting

The air curtain range can be adapted for vertical or horizontal installation. The units can also be installed recessed into suspended ceilings.

Horizontal mounting

The air curtain unit is installed horizontally with the supply air grille facing downwards as close to the door as possible. Minimum distance from outlet to floor for electrically heated units is 1800 mm. For other minimum distances, see fig. 3.

For the protection of wider openings, several units can be mounted next to each other using a joining kit (fig. 9).

A design kit for a neat installation that conceals cables, pipes and mountings is available for both wall and ceiling installations, see accessories pages.

Mounting with wall brackets PA34WB (fig. 6)

1. Remove the plastic covers on the wall brackets. (Fig. 6A)
2. Mount the brackets on the wall according to measures in fig. 6B.
3. Fasten the hammer head screws on the unit in the holes M8. (Fig. 5 and 6C)
4. Lock the nuts so that the hammer head screws are at 20 mm height. Note the direction of the screw heads. (Fig. 6C)
5. Slide the unit on the consoles. (Fig. 6D)
6. Lock the nuts against the bracket and put the plastic covers on again. (Fig. 6E)

Horizontal mounting on the ceiling

Threaded rods, wire suspension kits and ceiling brackets for ceiling mounting are available as accessories, see fig. 7 och 8 and separate manuals.

Horizontal recessed mounting in false ceilings

Outlet extension used for recessed installation is available as accessory, see fig. 10 and separate manual.

Vertical mounting PA3JK

Units from 1,5 metres and longer may be used vertically. For vertical mounting, all units must be supplemented with a vertical kit containing everything needed for a practical installation of floor standing units.

The unit can be reversed and placed on either side of the door. Connections and PC Board SIRE are positioned near floor level when the air curtain is placed to the left of the door and at the top when it is placed to the right (seen from the inside).

The accompanying floor edging is attached to the floor with fasteners appropriate to the surface.

Two units can be mounted directly on top of each other, the floor edging is then used as a joining bracket.

The air curtain must be secured to wall or ceiling.

A design kit which gives a neater installation that conceals cables and pipes is available as accessory, see accessories pages.

See fig. 11 and separate manual.

Electrical installation

The installation, which should be preceded by an omnipolar switch with a contact separation of at least 3 mm, should only be wired by a competent electrician and in accordance with the latest edition of IEE wiring regulations. The control system is pre-installed in the air curtain with an integrated control card, (see fig. 2).

SIRE is supplied pre-programmed with quick-fit connections.

Modular cables are connected to the control board. See manual for SIRE.

Unit without heating or with water heating

Connected via the built-in SIRE control board with 2 m cord and plug.

Unit with electrical heating

The electrical connection is made on the top of the unit (horizontal) or on the reverse (vertical). Control supply is 230V~ and cable is routed from the built-in SIRE control board. Power supply for heating (400V3 ~) is connected to terminal block in the terminal box. 2-metre and longer units require dual power supplies.

The largest cable diameter for the terminal block is 16 mm². The cable glands used must meet the protection class requirements. In the distribution board it is to be indicated that "the air curtains can be supplied from more than one connection".

See wiring diagrams.

Type	Output [kW]	Voltage [V]	Minimum area* [mm ²]
Control	0	230V~	1,5
PA3510E08	8	400V3~	2,5
PA3515E12	12	400V3~	4
PA4210E12	12	400V3~	4
PA4215E18	18	400V3~	10
PA3520E16*¹	8	400V3~	2,5
	8	400V3~	2,5
PA3525E20*¹	8	400V3~	2,5
	12	400V3~	4
PA4220E24*¹	12	400V3~	4
	12	400V3~	4
PA4225E30*¹	12	400V3~	4
	18	400V3~	10

*¹) 2 m and 2.5 m-units are connected with two power supplies, see p. 2. 2.5 meter units have electric batteries with two different effects, and the electric battery on the left, on a horizontal unit, seen from inside the room, has the highest effect.

*²) Dimensioning of external wiring shall comply with applicable regulations and local deviations may occur.

Start-up (E)

When the unit is used for the first time or after a long period of disuse, smoke or odour may result from dust or dirt that has collected on the element. This is completely normal and disappears after a short time.

Connecting the water coil (W)

The installation must be carried out by an authorised installer.

The water coil has copper tubes with aluminium fins and is suitable for connection to a closed water heating system. Steel connection pipe. The heating coil must not be connected to a mains pressure water system or an open water system.

Note that the unit shall be preceded by a regulating valve, see Frico valve kit.

The water coil is connected on top of the unit (horizontal mounting) or on the reverse (vertical mounting) via connections DN20 (3/4"), external thread. Flexible hoses are available as an accessory, see accessories pages.

The connections to the heating coil must be equipped with shut off valves (included in Frico valve kits) to allow problem free removal.

A vent valve should be connected at a high point in the pipe system. Air valves are not included.

For vertical installation and bottom water connection it is not possible to bleed the coil in the unit. Ensure that the water coil is filled with water and that no air remains, prior to commissioning. See fig. 4.

Our recommended solution is to use a T-connection and shut off valves. Small air bubbles may remain, but will disappear with normal operation. NOTE: Care must be taken when connecting the pipes. Use a wrench or similar to hold the air curtain connections to prevent straining of the pipes and subsequent water leakage during connection to water supply pipe-work.

Adjustment of the air curtain and air flow

The direction and speed of the air flow should be adjusted considering the load on the opening. Pressure forces affect the air stream and make it bend inwards into the premises (when the premises are heated and the outdoor air is cold).

The air stream should therefore be directed outwards to withstand the load. Generally speaking, the higher the load, the greater the angle that is needed.

Basic setting fan speed

The fan speed when the door is open is set using the control. Note that the air flow direction and fan speed may need fine adjustment depending on the loading of the door.

Filter (W)

The water coil is protected against dirt and blockage by an air filter which covers the coil face. In environments where the filter needs cleaning often, it is advisable to use an external intake filter (see accessories pages), which provides an easier maintenance, since the unit does not need to be opened.

Service, repairs and maintenance

For all service, repair and maintenance first carry out the following:

1. Disconnect the power supply.
2. Loosen the screws and raise the front panel.
The front is blocked in open position with the front hatch hook, see fig 1A or removed completely, see fig. 1B. The service hatch is removed by loosening the screws.
3. After service, repairs and maintenance fasten the service hatch and the front. When the front has been removed it is important to be sure it is firmly seated in the front locks again, see fig. 1B.

Maintenance

Unit with water heating:

The appliance filter should be cleaned regularly to ensure the air curtain effect and the heat emission from the device. How often depends on local circumstances. A clogged filter is not a risk, but the appliance function can fail.

1. Disconnect the power.
2. Loosen the screws and raise the front panel.
The front is blocked in open position with the front hatch hook, see fig 1A.
3. Remove the filter and vacuum clean or wash it. If the filter is clogged or damaged, it may need to be changed.

All units:

Since fan motors and other components are maintenance free, no maintenance other than cleaning is necessary. The level of cleaning can vary depending on local conditions. Undertake cleaning at least twice a year. Inlet and exhaust grilles, impeller and elements can be vacuum cleaned or wiped using a damp cloth. Use a brush when vacuuming to prevent damaging sensitive parts. Avoid the use of strong alkaline or acidic cleaning agents.

Overheating

The air curtain unit with electric heater is equipped with an overheat protector. If it is deployed due to overheating, reset as follows:

1. Disconnect the electricity with the fully isolated switch.
2. Allow the electrical coil to cool.
3. Determine the cause of overheating and rectify the fault.
4. Connect the air curtain again.

All motors are equipped with an integral thermal safety cut-out. This will operate, stopping the air curtain should the motor temperature rise too high. The cut-out will automatically reset when the motor temperature has returned to within the motor's operating limits.

Temperature control

Temperature control of SIRE maintains the exhaust temperature. If the temperature should exceed the preset value anyway the overheating alarm goes off. For more information see the manual for SIRE.

Fan replacement

1. Determine which of the fans is not functioning.
2. Disconnect the cables to the relevant fan.
3. Remove the screws securing the fan and lift the fan out.
4. Install the new fan as above in reverse order.

Replacing heating elements (E)

1. Mark and disconnect the cables to the electric coil package.
2. Remove the mounting screws securing the electric coil package in the unit and lift it out.
3. Replace faulty electric coil.
4. Install the electric coil package in reverse order to the above.

Replacing the water coil (W)

1. Shut off the water supply to the unit.
2. Disconnect the connections to the water coil.
3. Remove the mounting screws securing the coil in the unit and lift the coil out.
4. Install the new coil in reverse order to the above.

Trouble shooting

If the fans are not working or do not blow properly, check the following:

- That the intake grille/filter is not dirty.
- Functions and settings of the SIRE control system, see manual for SIRE.

If there is no heat, check the following:

- Functions and settings of the SIRE control system, see manual for SIRE.

For units with electrical heating, also check the following:

- Power supply to electric heater coil; check fuses and circuit-breaker (if any).
- That the overheat protection for the motors has not been deployed.

For units with water coil, also check the following:

- That the water coil is air free.
- That there is enough water flow.
- That incoming water is heated enough.

If the fault cannot be rectified, please contact a qualified service technician.

Residual current circuit breaker (E)

When the installation is protected by means of a residual current circuit breaker, which trips when the appliance is connected, this may be due to moisture in the heating element. When an appliance containing a heater element has not been used for a long period or stored in a damp environment, moisture can enter the element.

This should not be seen as a fault, but is simply rectified by connecting the appliance to the main supply via a socket without a safety cut-out, so that the moisture can be eliminated from the element. The drying time can vary from a few hours to a few days. As a preventive measure, the unit should occasionally be run for a short time when it is not being used for extended periods of time.

Packaging

Packaging materials are chosen with consideration to environment and are therefore recyclable.

Handling of product at end of working life

This product may contain substances necessary for functionality of product but

potentially dangerous for the environment. The product should not be disposed mixed with general household waste but delivered to a designated collection point for environmental recycling. Please contact local authority for further details of your nearest designated collection point.

Safety

- *For all installations of electrically heated products should a residual current circuit breaker 300 mA for fire protection be used.*
- *Keep the areas around the air intake and exhaust grilles free from possible obstructions!*
- *The unit must not be fully or partially covered as overheating can result in a fire risk!*
- *Lifting equipment must be used to lift the unit.*
- *This appliance can be used by children aged from 8 years and above and persons with reduced physical, sensory or mental capabilities or lack of experience and knowledge if they have been given supervision or instruction concerning use of the appliance in a safe way and understand the hazards involved. Children shall not play with the appliance. Cleaning and user maintenance shall not be made by children without supervision.*
- *Children of less than 3 years should be kept away unless continuously supervised.*
- *Children aged from 3 years and less than 8 years shall only switch on/off the appliance provided that it has been placed or installed in its intended normal operating position and they have been given supervision or instruction concerning use of the appliance in a safe way and understand the hazards involved.*
- *Children aged from 3 years and less than 8 years shall not plug in, regulate and clean the appliance or perform user maintenance.*

CAUTION — *Some parts of this product can become very hot and cause burns. Particular attention has to be given where children and vulnerable people are present.*